

SYSTEM-FREE ACCESSORIES CATALOGUE

Edition 04.2019
Ref. No. 8103.258

Quality management
certified according
to DIN EN ISO 9001

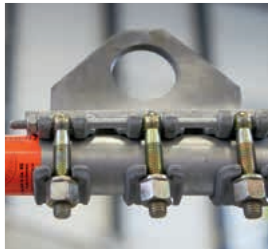



COMPANY FROM PAGE 4



Quality Made by Layher	4
More Speed	5
More Safety	5
More Proximity	5
More Simplicity	5
More Future	5

MAIN ACCESSORIES FROM PAGE 6



Base plates and accessories	6
Lattice beams, lattice beams connectors	6
Scaffolding tubes and couplers	12
Tools	14
Anchoring, testing and measuring equipment, scaffolding identification	16

ADVANCED ACCESSORIES FROM PAGE 18

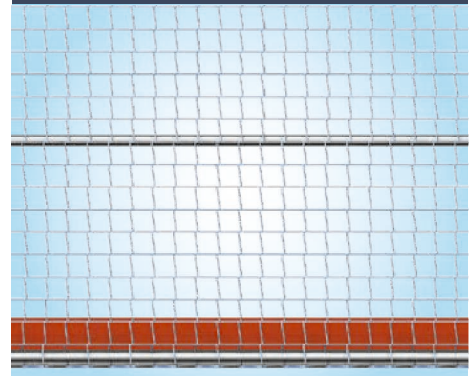

Suspended scaffolding	18
Standard brick guard and protection for pedestrians	18
Parts for rolling towers	20
Scaffolding enclosures	22
Ladder access	24
Scaffolding pallets	26
Bridging	28
Scaffolding planks	30

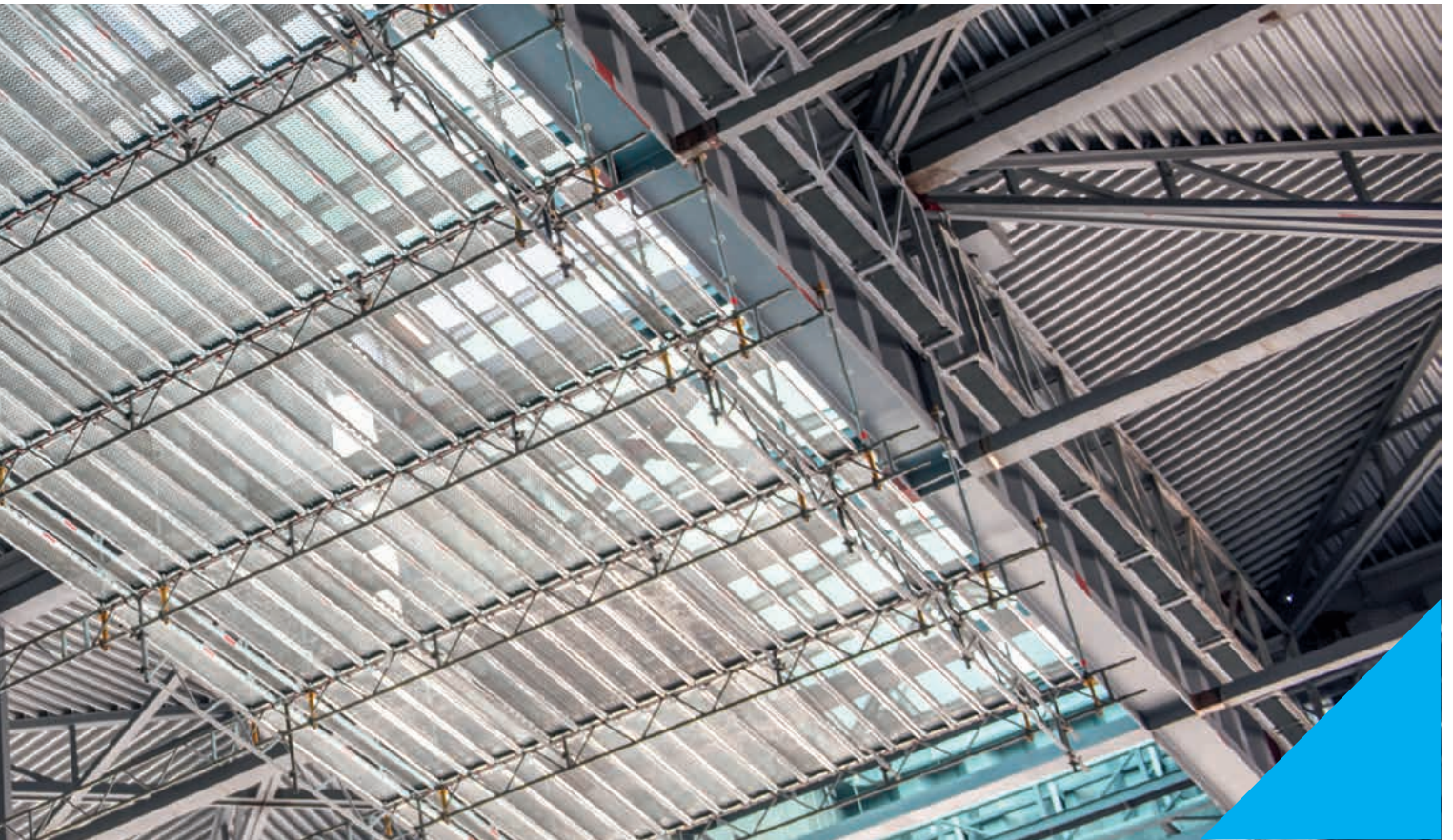

PLANNING AND SAFETY FROM PAGE 30



Software for scaffolding construction	30
Fall protection	32
Vertical transport	34
Various accessories	36

PRODUCT-PORTFOLIO



The Layher product range – all catalogues at a glance	
Speedyscaf System	Ref. No. 8102.260
Allround Scaffolding	Ref. No. 8116.256
System-free Accessories	Ref. No. 8103.258
Protective Systems	Ref. No. 8121.258
Event Systems	Ref. No. 8111.231
Access Technology	Ref. No. 8118.230

NOTICE

All dimensions and weights are guideline values, Subject to technical modification.

Steel components are galvanized according to EN ISO 1461 and DAST guideline 022. Connection parts are galvanized according to EN ISO 4042.

Our deliveries shall be made exclusively in accordance with our currently valid General Terms of Sale. These include the following provisions: The place of performance is Gueglingen-Eibensbach. Title to the delivered goods shall be retained until full payment has been made.

Please request the specific instructions for assembly and use when ordering. Protected by copyright. Not to be reproduced, either in whole or in part. Misprints and errors excepted.

QUALITY MADE BY LAYHER



Headquarters in Eibensbach



Plant 2 in Gueglingen

HERE IS THE BEATING HEART OF LAYHER.

Quality made by Layher comes from Gueglingen-Eibensbach. Our company has set down deep local roots since it was established. Right up until today, development, production, logistics and management are all in one place, where the conditions are best for achieving quality made by Layher: in Gueglingen-Eibensbach. The two locations together cover a surface area of 318,000 m². This includes more than 148,000 m² of covered production and storage areas. This is where our scaffolding systems are created by highly automated production. Short distances and short reaction times mean we can adapt production to suit our customers' requirements, flexibly and at any time.

MORE POSSIBILITIES. THE SCAFFOLDING SYSTEM.

This brand promise made by Layher is the expression of a brand philosophy that we've been living by for over 70 years. More speed, more safety, more proximity, more simplicity and more future: values with which we strengthen our customers' competitiveness in the long term. With our innovative systems and solutions, we're working all the time on making scaffolding construction even simpler, even more economical and, above all, even safer. With comprehensive services, a permanent range of training courses and an ethos of customer focus, more than 1,900 dedicated Layher employees are creating more possibilities for our customers every single day. In 40 countries all over the world.



MORE INFORMATION

Discover the world of Layher in its company film at:

yt-image-en.layher.com



MORE SPEED

High level of material availability, effective delivery service and quick assembly and dismantling of the scaffolding systems thanks to 100% fitting accuracy.

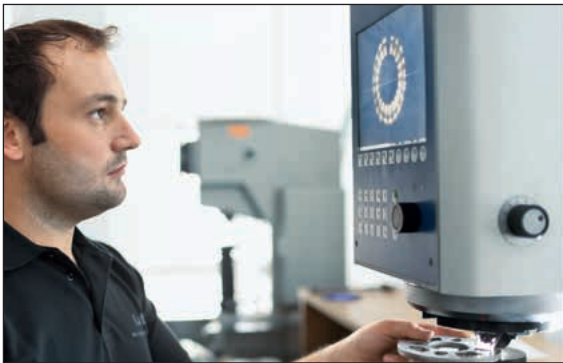

MORE SAFETY

Outstanding quality and precision coupled with a long service life – confirmed internationally through independent certifications, inspections and approvals. Continuity and long-term partnership.

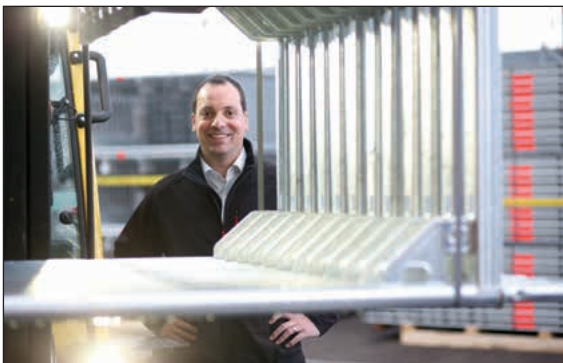

MORE PROXIMITY

Comprehensive personal consultation and close-knit delivery network. Global presence through our own subsidiaries. Family-owned company that works closely with its customers.



MORE SIMPLICITY

Economical scaffolding systems that have been proven in practice, available with an extensive product range. Cross-system combinations for versatile use. Rapid decision making thanks to efficient structures and processes.



MORE FUTURE

Thanks to permanent product innovations and the improvement of existing parts. By opening up new areas of business. With an integrated system to ensure high profitability and retention of investment value. Through an extensive range of training opportunities and seminars to ensure that customers are always right up-to-date with the latest technical and commercial developments.

Base plates and accessories

To adjust to the ground, choose between the non-height-adjustable **base plate 1** or height-adjustable **base plates 2-6** with sturdy and selfcleaning round threads, with colour and notch markings to provide protection against overwinding. Make sure that there are sufficient load-distributing surfaces.

The round threads of all Layher scaffolding spindles have an outside diameter of 38 mm. The wing external dimension of the spindle nut is 205 mm. The dimensions of the foot plate are 150 x 150 mm.

Load capabilities of spindle cross-section as per DIN EN 12811-1, Annex B

Spindle type	N_{Rd} [kN]	M_{Rd} [kNcm]	V_{Rd} [kN]
normal	97.7	83.0	36.0
reinforced	119.9	94.5	44.1
solid	288.0	157.0	106.0

The **swivelling head jack 8** can be used to install supports (e.g. wood sections) with an inclination of up to max. 5% to the horizontal in the longitudinal and transverse directions, thus eliminating the need to level with a wedge. Greater loads can be supported thanks to the articulated mounting of the top plate and the resulting centric introduction of vertical forces into the spindles.

The **cross head jack 45, solid 10** serves to accommodate wood sections, glued binders or steel beams in falsework and supporting scaffolding. It stabilises the supports against tilting, and it is possible to use one or two formwork supports. Height adjustment is performed using the spindle nut. The cross head jack is suitable for all common formwork supports.

The **protective base for base plates 11** conserves sensitive floorings from damages made of the base plate. By using the **adjustment plate 12**, base plates with steep plate can be used on inclined ground. By turning the top against the bottom part, the inclination from 0 to 16% can be adjusted. The load increasing static remains completely.

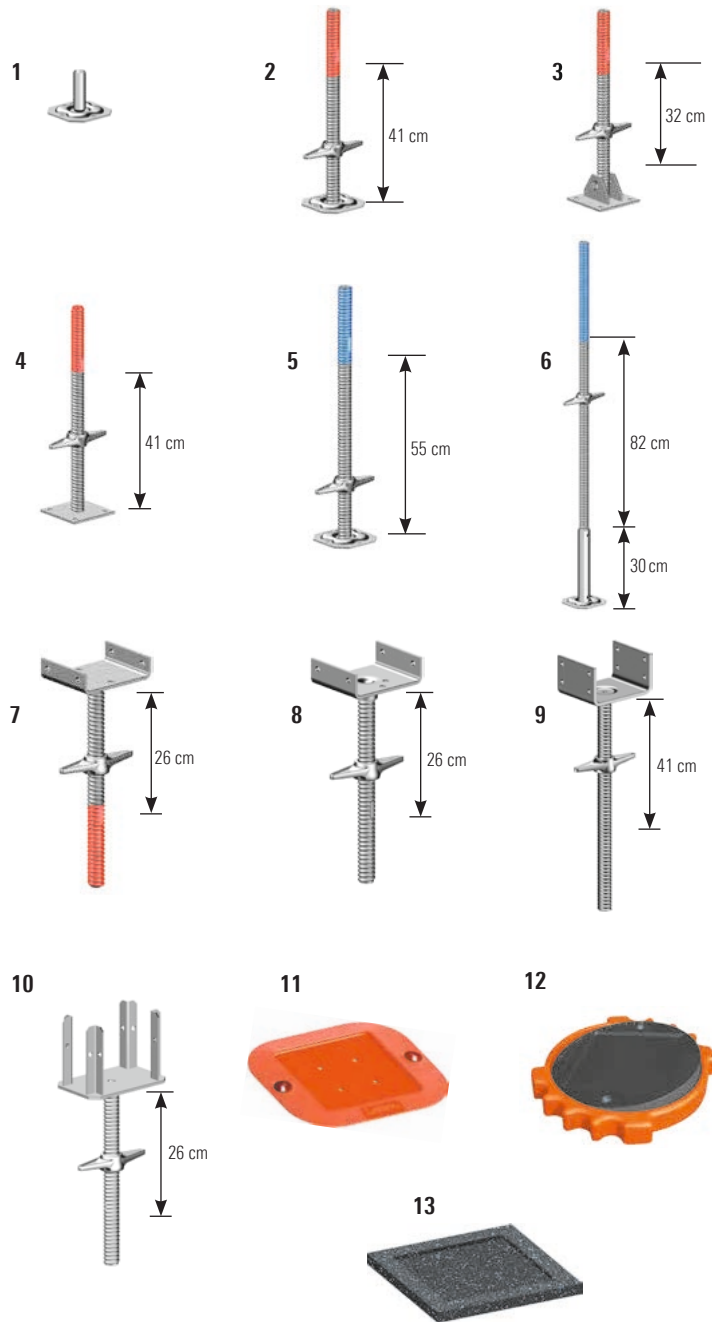

Lattice beams, lattice beam connectors

Lattice beams of steel and aluminium are used to provide:

- ▶ Bridging
- ▶ Projections and strengthening
- ▶ Roof structures and enclosures
- ▶ Surface scaffolding

The top and bottom chords and the end posts have an external diameter of 48.30 mm and are designed for the connection of scaffolding couplers.



Pos.	Description	Dimensions L/H x W [m]	Weight approx. [kg]	PU [pcs.]	Ref. No.
1	Base plate without height adjustment	0.11	1.0	250	4001.000
2	Base plate 60 (max. spindle travel 41 cm)	0.56	3.6	200	4001.060
3	Swivelling base plate 60 , reinforced (max. spindle travel 32 cm), ensure sufficient structural strength	0.58	6.1	250	4003.000
4	Base plate 60 , solid, without lock (max. spindle travel 41 cm)	0.58	6.7	200	5602.060
5	Base plate 80 , reinforced (max. spindle travel 55 cm)	0.73	4.9	200	4002.080
6	Base plate 150 , reinforced (max. spindle travel 82 cm), ensure sufficient structural strength	1.50	10.0	25	4002.130
7	Head jack 45 , solid, 16 cm (max. spindle travel 26 cm), width of fork 16 cm	0.45	6.6	100	5314.045
8	Swivelling head jack 45 , solid, 16 cm (max. spindle travel 26 cm), width of fork 16 cm	0.45	7.3	150	5312.045
9	Head jack 60 , reinforced, 18 cm (max. spindle travel 41 cm), width of fork 18 cm	0.60	8.0	100	5316.060
10	Cross head jack 45 , solid (max. spindle travel 26 cm), opening dimensions 8.50 / 17 cm	0.45	6.9	90	5315.045
11	Protective base for base plate of polypropylene, with 2 reflectors	0.27 x 0.24	2.1	10	4007.005
12	Adjustment plate for base plate of glass-fibre-reinforced polyamide plastic, inclination 0 – 16%	Ø 0.30	1.3	250	4000.400
13	Rubber pad for base plate for slip-reduction on solid grounds like concrete, asphalt, stone or timber. Protects sensitive deckings from damages.	0.20 x 0.20	0.4		4000.500

Pos.	Description	Dimensions L/H x W [m]	Weight approx. [kg]	PU [pcs.]	Ref. No.
14	Steel system lattice beam 450 LW , 45 cm high, 2.25 m long*	2.25 x 0.45	21.8	40	4925.225
		3.25 x 0.45	30.9	40	4925.325
		4.25 x 0.45	40.0	40	4925.425
		5.32 x 0.45	49.5	40	4925.532
		6.32 x 0.45	59.0	40	4925.632

WS = wrench size PU = packaging unit = available ex works = delivery time on request = only available in this packaging unit = the approval process is not yet completed

*Not part of the type calculation

System lattice beam 450 steel/aluminium

Possible bay divisions

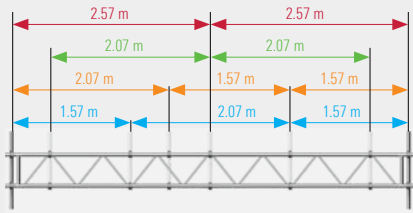

The following bay length combinations are possible with the **5.32 m long lattice beam**:

- ▶ 1.57 m + 2.07 m + 1.57 m
- ▶ 1 x 2.07 m + 2 x 1.57 m
- ▶ 2 x 2.07 m
- ▶ 2 x 2.57 m

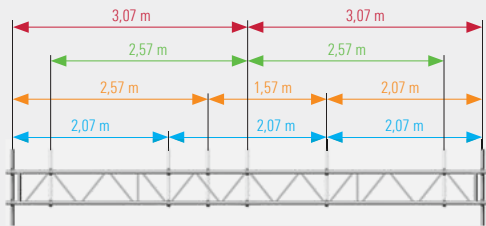

The following bay length combinations are possible with the **6.32 m long lattice beam**:

- ▶ 3 x 2.07 m
- ▶ 1 x 2.57 m + 1 x 1.57 m + 1 x 2.07 m
- ▶ 2 x 2.57 m
- ▶ 2 x 3.07 m

The lattice beams Ref. No. 4925, Ref. No. 4922, Ref. No. 4902, Ref. No. 4904 and Ref. No. 4903 are connected to one another using **unit beam spigot T16 dia. 38 mm 2** and **lattice beam hinged pins, dia. 12 mm 4** or **special bolt M12 x 60, with nut 5**.

For lattice beams Ref. No. 4925, Ref. No. 4922, Ref. No. 4917 Ref. No. 4902, Ref. No. 4903, Ref. No. 4904 und Ref. No. 4906 the following applies: the standard lengths are extended using lattice beam connectors. Loading tables available on request.

In conjunction with the **unit beam spigots T4 dia. 38 mm, cranked 3** and standard lattice beams, 45 cm high, made from aluminium or steel, double-pitch roof structures (roof pitch 11°) can be built.

Steel lattice beams 750 6, 75 cm high, of steel design, are used to support high loads or to bridge wider spans. Loading tables available on request.

The heavy-duty lattice beams Ref. No. 4906 are connected to one another with **unit beam spigots round steel 7** and **lattice beam pin dia. 14 x 77 mm 8**, with **safety clip 2.8 mm 9**, or **special bolts M14 x 65 mm, with nut 10**.

The **aluminium lattice beam 750 11** is the lighter alternative for supporting higher loads or for bridging wider spans. Loading tables available on request.

For mounting at the end, **passageway markings 12** with rotating half-couplers are available. The retro-reflecting surface conforms to the requirements of the German RSA (part 2).





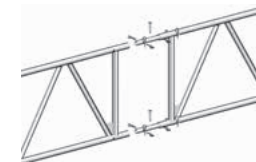
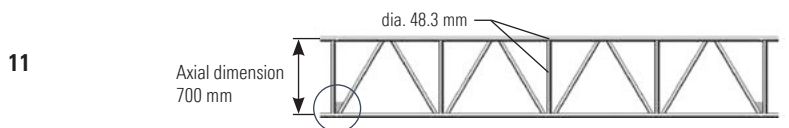
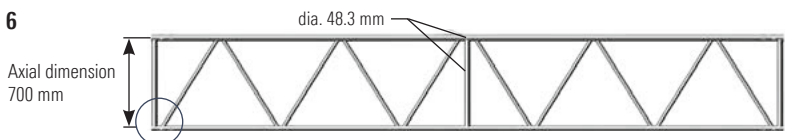
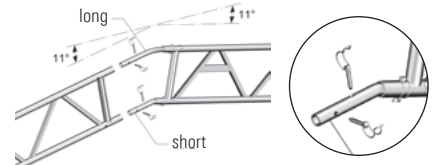
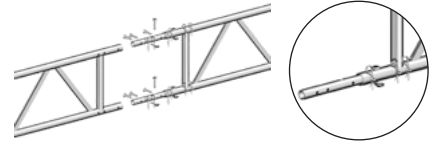



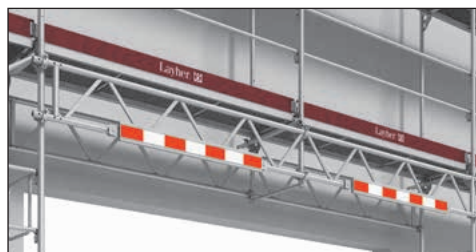















Coupler connection as in sketch possible for Ref. No. 4902



12



Pos.	Description	Dimensions L/H x W [m]	Weight approx. [kg]	PU [pcs.]	Ref. No.
1	Aluminium system lattice beam 450 , 45 cm high, aluminium, more than 50% weight saving compared to steel				
	2.25 m long	2.25 x 0.45	9.4	50	4904.225
	3.25 m long	3.25 x 0.45	14.4	50	4904.325
	4.25 m long	4.25 x 0.45	17.8	50	4904.425
	5.32 m long	5.32 x 0.45	21.7	50	4904.532
	6.32 m long	6.32 x 0.45	24.9	50	4904.632
	Aluminium lattice beam 450 , 45 cm high, aluminium, more than 50% weight saving compared to steel 8.00 m long, with type calculation	8.00 x 0.45	32.7	50	4902.800
2	Unit beam spigot T16 , dia. 38 mm for straight extension of lattice beam Ref. No. 4912, Ref. No. 4922, Ref. No. 4902, Ref. No. 4903, Ref. No. 4904, Ref. No. 4925	0.54	2.4		4925.000
3	Unit beam spigot T4 , dia. 38 mm, cranked, long for angular extension of lattice beam (45 cm high) at top chord, for double-pitch roof structures, roof pitch 11°	0.62	2.6		4922.001 
	Unit beam spigot T4 , dia. 38 mm, cranked, short for angular extension of lattice beam (45 cm high) at top chord, for double-pitch roof structures, roof pitch 11°	0.48	1.9		4922.002 
4	Lattice beam hinged pin , dia. 12 mm, with pan head	Required: 4 pcs.	2.0	20 	4905.667
5	Special bolt M12 x 60 , with nut	Required: 4 pcs.	4.0	50 	4905.061
6	Steel lattice beam 750 , 75 cm high				
	2.00 m long	2.00 x 0.75	35.5	20	4906.200 
	3.00 m long	3.00 x 0.75	48.5	20	4906.300 
	4.00 m long	4.00 x 0.75	61.0	20	4906.400 
	5.00 m long	5.00 x 0.75	78.0	20	4906.500 
	6.00 m long	6.00 x 0.75	90.0	20	4906.600 
	7.00 m long	7.00 x 0.75	102.5	20	4906.700 
7	Unit beam spigot , round steel, dia. 36 mm for extending lattice beam Ref. No. 4906	0.44	3.4		4916.000
8	Lattice beam pin , dia. 14 x 77 mm	Required: 4 pcs.	2.2	20 	5906.078 
9	Safety clip , 2.8 mm	Required: 4 pcs.	0.5	50 	4905.001
10	Special bolt M14 x 65 , with nut	Required: 4 pcs.	6.5	50 	4908.066 
11	Aluminium lattice beam 750 , 75 cm high, aluminium				
	2.25 m long, with type calculation	2.25 x 0.75	14.0	25	4903.225 
	3.25 m long, with type calculation	3.25 x 0.75	19.5	25	4903.325 
	4.25 m long, with type calculation	4.25 x 0.75	26.0	25	4903.425 
	5.25 m long, with type calculation	5.25 x 0.75	32.1	25	4903.525 
	6.25 m long, with type calculation	6.25 x 0.75	38.1	25	4903.625 
	7.25 m long, with type calculation	7.25 x 0.75	44.2	25	4903.725 
12	Passageway marking 1.50 m with rotating half-couplers	1.5	5.3	70	1788.150 

WS = wrench size PU = packaging unit  = available ex works  = delivery time on request  = only available in this packaging unit  = the approval process is not yet completed

Lattice beams, lattice beam connectors, section beams

The **aluminium tri-lite beam 1** is a lightweight multipurpose beam. It is suitable for use as a beam subjected to bending stress, as a vertical support and as a light crosspiece, and is resistant to buckling and tilting without additional stiffening. External dimensions 45 x 45 x 45 cm, coupler connection dia. 48.3 mm possible, extension of beams with lattice beam connectors Ref. No. 4925.000 lattice beam connector T16 and special bolts Ref. No. 4905.060 or bolts Ref. No. 4905.065 with safety clips Ref. No. 4905.000. Loading tables available on request.

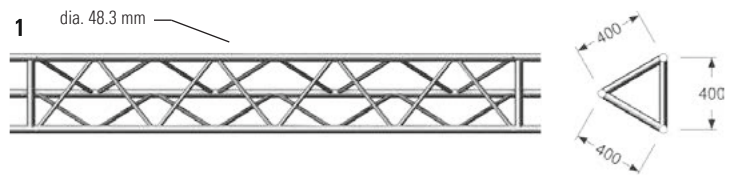

Tri-struts LW 2 are designed for high loadbearing applications, also in temporary hall construction in conjunction with lattice beams Ref. Nos. 4912, 4922, scaffolding tubes and couplers. They therefore serve as supporting structures for mono-pitch and double-pitch roofs and for special solutions. The three scaffolding tubes of the triangular support each have an external diameter of 48.3 mm and a wall thickness of 2.7 mm. The tri-strut has external dimensions of 22 x 22 x 22 cm and is designed for the connection of dia. 48.3 mm scaffolding couplers. Loading tables available on request.

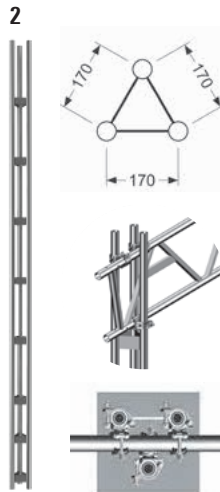

View onto lattice beam in triangular support, lattice beam is connected by swivel couplers to the support



The **three-point base plate T18 3** is used to form the base for the tri-strut Ref. No. 4911 and to divert the load into the ground.

Aluminium U-profile with half couplers 4

For screwing on a lattice beam to carry serial decks; Working surface without any trip hazards. Thanks to the half couplers, the U-profile can be installed on any lattice beam with tubing dia. 48.3 mm.



Lattice beam mounting 0.40 m 6

Wall connection for standard lattice beams Ref. Nos 4912, 4922, 4925 and 4902 for bridging structures and similar, structural strength calculation required.



The **aluminium section beam with wood 7** is a lightweight aluminium beam with low overall height for birdcage scaffolding, walkways and bridging. Double-webbed beam of aluminium, 160 mm high, 1 flange 115 mm wide, with T-groove for connections with grooved bolts, 1 flange 100 mm wide, with replaceable wood section insert, for nailed or bolted connections. Loading tables available on request.

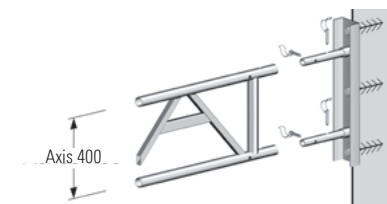
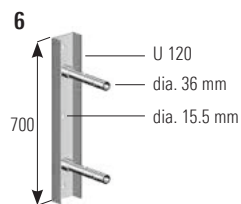

For screws and bolts see page 8 and 9

Beam connector, 1.20 m 8

Holes drilled 10 cm apart. For continuous straight-line extension of aluminium section beams – variable joint. Permits adjustment of the aluminium section beams to the site dimensions. Rectangular tube, 40 x 80 mm cross section, steel, hot-dip galvanized.

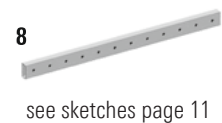
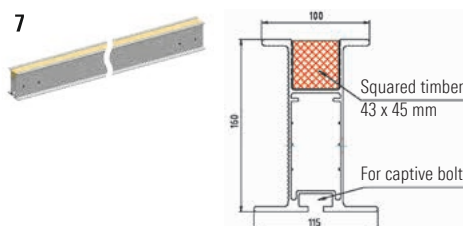

see sketches page 11

Pos.	Description	Dimensions L/H x W [m]	Weight approx. [kg]	PU [pcs.]	Ref. No.
1	Aluminium tri-lite beam 3.00 m long 4.00 m long 5.00 m long 6.00 m long	3.00 x 0.45	25.0	8	4917.300 🏠
		4.00 x 0.45	34.0	8	4917.400 🏠
		5.00 x 0.45	41.0	8	4917.500 🏠
		6.00 x 0.45	50.0	4	4917.600 🏠
2	Tri-strut LW, steel, hot-dip galvanized 3.00 m long 4.00 m long 5.00 m long 6.00 m long	3.00 x 0.22	36.2	35	4911.300 🏠
		4.00 x 0.22	47.3	35	4911.400 🏠
		5.00 x 0.22	59.9	35	4911.500 🏠
		6.00 x 0.22	71.0	35	4911.600 🏠
3	Three-point base plate T18, hot-dip galvanized for tri-strut LW No. 4911 with 3 spigots	0.40 x 0.40	14.8	40	4911.001 🏠
4	Aluminium U-profile with half couplers 3.00 m long 3.00 m long 3.25 m long 3.25 m long 4.00 m long 4.00 m long 4.25 m long 4.25 m long 5.00 m long 5.00 m long 5.32 m long 5.32 m long 6.00 m long 6.00 m long 6.32 m long 6.32 m long	WS 19 3.00	7.1	50	4909.319 🕒
		WS 22 3.00	7.1	50	4909.322 🕒
		WS 19 3.25	7.7	50	4919.319 🕒
		WS 22 3.25	7.7	50	4919.322 🕒
		WS 19 4.00	9.3	50	4909.419 🕒
		WS 22 4.00	9.3	50	4909.422 🕒
		WS 19 4.25	9.9	50	4919.419 🕒
		WS 22 4.25	9.9	50	4919.422 🕒
		WS 19 5.00	11.5	50	4909.519 🕒
		WS 22 5.00	11.5	50	4909.522 🕒
		WS 19 5.32	12.2	50	4919.519 🕒
		WS 22 5.32	12.2	50	4919.522 🕒
		WS 19 6.00	13.8	50	4909.619 🕒
		WS 22 6.00	13.8	50	4909.622 🕒
		WS 19 6.32	14.5	50	4919.619 🕒
		WS 22 6.32	14.5	50	4919.622 🕒
5	Universal U-Lift-off preventer	WS 19	1.0	500	2635.000 🏠
6	Lattice beam mounting, 0.40 m	0.70	12.1	80	4920.040 🏠
7	Aluminium section beam with wood, with riveted-in wood section, with holes drilled for connection by means of beam connectors 3.00 m long 4.00 m long	3.00	18.0	48	4026.300 🕒
		4.00	24.0	48	4026.400 🕒
8	Beam connector, 1.20 m	1.20	6.6	100	4026.000 🕒
9	Beam connector bolt M12 x 70, with nut		0.7	10	4026.002 🏠 📦

For connecting individual **aluminium section beams with wood 7** Ref. No. 4026 a **beam connector 8, 1.20 m** Ref. No. 4026.000 and four **beam connector bolts 9 M12 x 70,** with nut Ref. No. 4026.002 are required for each.

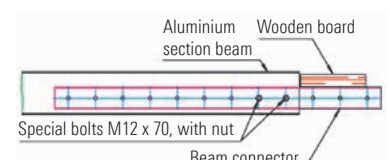
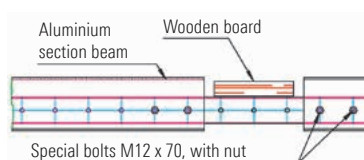

WS = wrench size PU = packaging unit 🏠 = available ex works 🕒 = delivery time on request 📦 = only available in this packaging unit ⚙️ = the approval process is not yet completed

Scaffolding tubes and couplers

General assembly and extension

Standardised scaffolding tubes in steel (hot-dip galvanized) or aluminium permit, in conjunction with scaffolding couplers, special assembly and extension outside the regular version.

The **33 mm steel tube, 1.50 m 2** is intended for use with the steel deck T4. Special assemblies differ from the regular version, their stability must be verified.

Scaffolding couplers

Connections, in steel, drop-forged; as per DIN EN 74 and general building authority approval from the DIBt (German Civil Engineering Institute). Tightening torque of collar nuts 50 Nm.

The **half-coupler with hook 4** becomes in conjunction with a steel scaffolding tube a length-adjustable wall tie

Double coupler 5



Lattice beam coupler 11

Example for use of the lattice beam coupler



Wedge spindle swivel coupler 14

Example of the use of the Wedge spindle swivel coupler

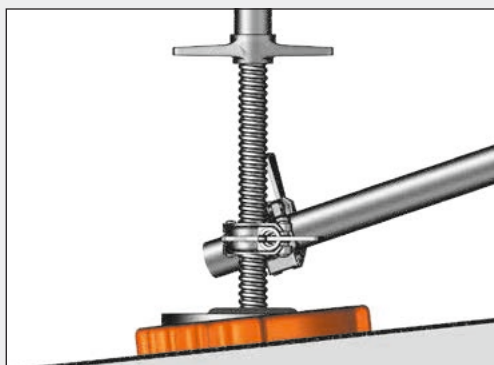

Is used in conjunction with Ref. No. 4600 for anchoring.



For right-angled connection of tubes with dia. 48.3 mm



For connection at any angle of tubes with dia. 48.3 mm

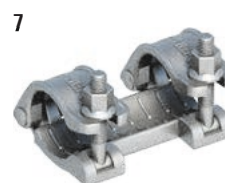

For connection of two tubes with dia. 48.3 mm in one axis. Only in conjunction with EN spigot Pos. 8



Only in conjunction with sleeve coupler Pos. 7



For right-angled connection of tubes with dia. 48.3 mm



For connection at any angle of tubes with dia. 48.3 mm



For 90° connection on the axis of tubes with dia. 48.3 mm



For right-angled connection of a tube dia. 33.7 mm to a tube of dia. 48.3 mm



For connection at any angle of a tube dia. 33.7 mm to a tube of dia. 48.3 mm



For connection of a tube dia. 48.3 mm to a scaffolding spindle at any angle



For right-angled connection of a tube dia. 60.3 mm to a tube of dia. 48.3 mm



For right-angled connection of a tube dia. 60.3 mm to a tube of dia. 48.3 mm

Pos.	Description	Dimensions L/H x W [m]	Weight approx. [kg]	PU [pcs.]	Ref. No.
1	Scaffolding tube , steel, hot-dip galvanized Scaffolding tubes dia. 48.3 x 4.0 mm, as per DIN EN 39	0.50	2.3	250	4600.050
		1.00	4.5	61	4600.100
		1.50	6.8	61	4600.150
		2.00	9.0	61	4600.200
		2.50	11.3	61	4600.250
		3.00	13.5	61	4600.300
		3.50	15.8	61	4600.350
		4.00	16.7	61	4600.400
		5.00	22.7	61	4600.500
		5.50	25.0	61	4600.550
		6.00	25.0	61	4600.600
2	33 mm steel tube , 1.50 m Scaffolding tubes dia. 33.7 x 2.25 mm	1.50	3.0	100	4603.150
3	Scaffolding tube , aluminium Scaffolding tubes dia. 48.3 x 4.0 mm	0.50	0.8	250	4601.050
		1.00	1.5	61	4601.100
		1.50	2.3	61	4601.150
		2.00	3.8	61	4601.200
		2.50	3.7	61	4601.250
		3.00	4.5	61	4601.300
		3.50	5.3	61	4601.350
		4.00	6.0	61	4601.400
		4.50	6.8	61	4601.450
		5.00	7.5	61	4601.500
		5.50	8.3	61	4601.550
		6.15	9.2	104	4601.600
		8.00	12.1	104	4601.800
4	Half coupler with hook	WS 19	0.8	25	4749.019
5a	Double coupler Class BB, EN 74-1 RA BB C3 M quality-monitored, for use in class B and BB on steel and aluminium tube	WS 19	1.3	25	4700.019
		WS 22	1.3	25	4700.022
5b	Double coupler with coarse thread Description as Pos. 5a acc. to approval Z-8.331-947	WS 19	1.3	25	4777.019
		WS 22	1.3	25	4777.022
6a	Swivel coupler Class B, EN 74-1 SW B C3 M. quality-monitored, for use in class B on steel and aluminium tube	WS 19	1.5	25	4702.019
		WS 22	1.5	25	4702.022
6b	Swivel coupler with coarse thread Description as Pos. 6a acc. to approval Z-8.331-947	WS 19	1.5	25	4778.019
		WS 22	1.5	25	4778.022
7	Sleeve coupler Class B, EN 74-1 SF B C3 M, quality-monitored, for use in class B on steel and aluminium tube	WS 19	1.8	25	4703.019
		WS 22	1.8	25	4703.022
8	Internal spigot Description as Pos. 7	0.20	1.2	25	4739.000
9	Wedge double coupler Class B, DIN EN 74-B-C, on steel and aluminium tube		1.6	25	4727.000
10	Wedge swivel coupler Class A, DIN EN 74-A-C, on steel and aluminium tube		1.8	25	4728.000
11	Lattice beam coupler for lattice beam and tubes dia. 48.3 mm	WS 19	1.6	25	4720.019
		WS 22	1.6	25	4720.022
12	Reduction double coupler , 48.3 x 33.7 mm	WS 19	1.3	25	4737.019
		WS 22	1.3	25	4737.022
13	Reduction swivel coupler , 48.3 x 33.7 mm	WS 19	1.6	25	4738.019
		WS 22	1.6	25	4738.022
14	Wedge spindle swivel coupler		1.8	25	4735.000
15	Reduction double coupler , 60.3 x 48.3 mm	WS 22	1.9	25	4744.022
16	Reduction swivel coupler , 60.3 x 48.3 mm	WS 22	2.3	25	4745.022

WS = wrench size PU = packaging unit = available ex works = delivery time on request = only available in this packaging unit = the approval process is not yet completed

Scaffolding tubes and couplers

Half-couplers

with screw and wedge connection for use on steel and aluminium tubes in accordance with approval Z-8.331-882.

Wedge half-coupler 5

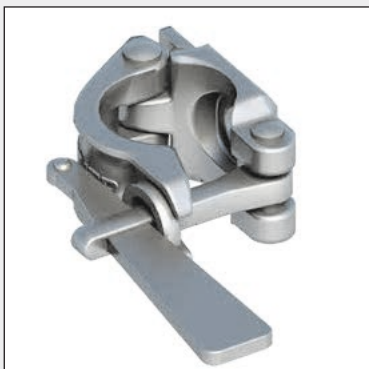

Half-coupler 6

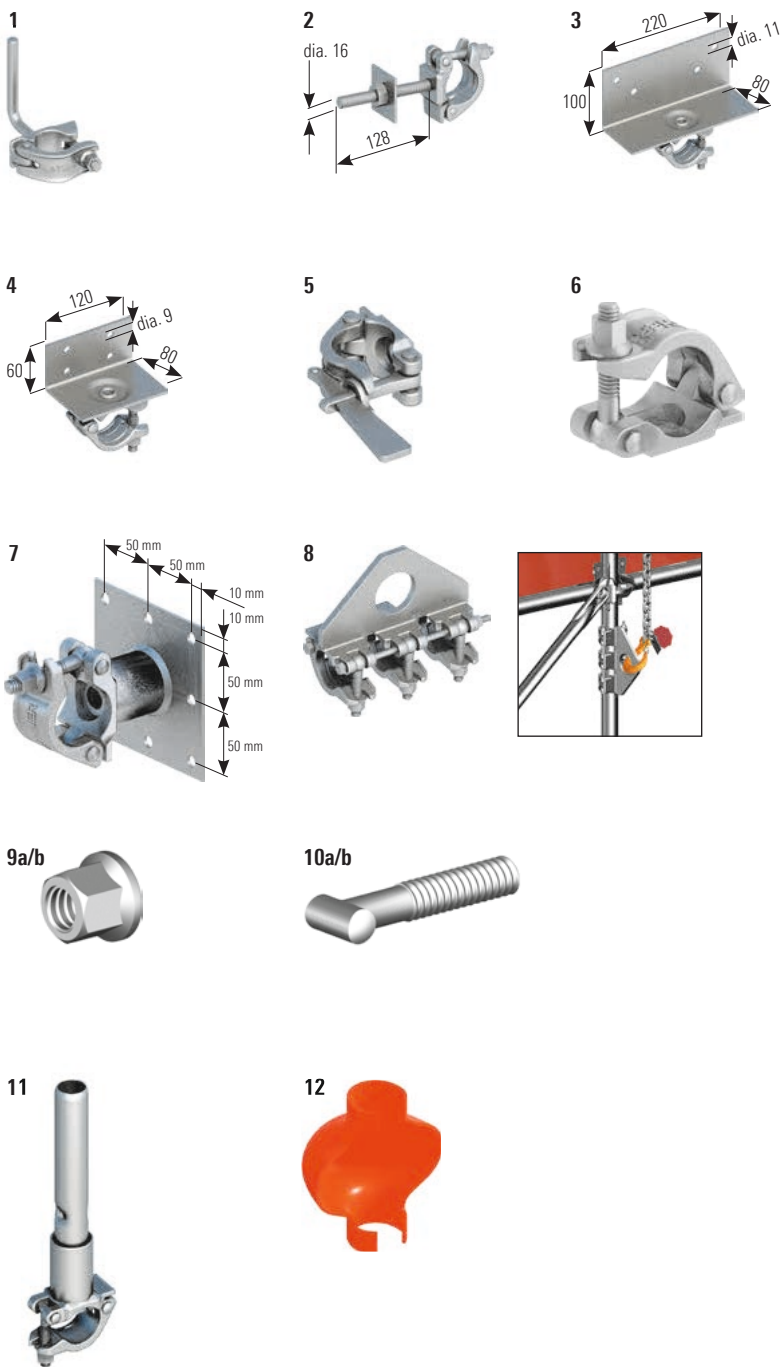

Tools

The high-quality **scabbling pick 16** on the hammer head ensures a consistently safe use. The additional hardened inner tube provides a standard breaking strength. In addition, the reinforced scabbling pick has a patented head-stem-connection, which also forgives failures. The orange handle provides good handling, good cushioning and low-fatigue working.



With reversing lever for right-hand and left-hand operation

Pos.	Description		Dimensions L/H x W [m]	Weight approx. [kg]	PU [pcs.]	Ref. No.
1	Half-coupler with toe board pin	WS 19		1.0	25	4708.019
		WS 22		1.0	25	4708.022
2	Combination coupler connects scaffolding tubes to wooden parts	WS 19		1.1	25	4711.019
3	Squared timber coupler, large with steel bracket for holding wood sections, e.g. 10 x 12 cm	WS 19	0.22	1.9	25	4717.019
		WS 22		1.9	25	4717.022
4	Squared timber coupler, small with steel bracket for holding wood sections, e.g. 8 x 8 cm	WS 19	0.12	1.4	25	4718.019
		WS 22		1.4	25	4718.022
5	Wedge half-coupler Class A, quality-monitored, with approval Z-8.331-882, for use in class A on steel and aluminium tube			0.9	25	4729.000
6	Half-coupler with eye bolt Class B, quality-monitored, with approval Z-8.331-882, for use in class B on steel and aluminium tube	WS 19		0.8	25	4707.019
		WS 22		0.8	25	4707.022
7	Half-coupler with plate Connection of wall panels to scaffolding tubes	WS 19	0.12 x 0.12	1.5	25	4705.019
8	Crane eyelet coupler for crane positioning of roofs, scaffolding with a perm. load capacity of 14.1 kN upright or parallel to the tube axis	WS 19		3.3	25	4724.019
		WS 22		3.3	25	4724.022
9a	Collar nut standard thread M14	WS 19		1.8	50	6494.707
		WS 22		1.5	50	6494.708
9b	Collar nut standard thread M14 for rapid coupler, acc. to approval Z-8.331-947	WS 19		1.8	50	6494.553
		WS 22		2.4	50	6494.554
10a	T-bolt standard thread M14 82 mm			4.5	50	6494.537
10b	T-bolt standard thread M14 82 mm, for rapid coupler, acc. to approval Z-8.331-947			4.7	50	6494.555
11	Spigot with half coupler for extension on dia. 48.30 mm	WS 19	0.30	1.8	250	4706.019
		WS 22		1.8	250	4706.022
12	Cover for coupler with integrated reflector polyethylene, fixing with disposable tie 6241.001 (s. page 25, Pos. 4)			1.2	10	4007.009

Pos.	Description		Dimensions L/H x W [m]	Weight approx. [kg]	PU [pcs.]	Ref. No.
13	Ratchet spanner with reinforced head	WS 19	0.32	0.7		4740.019
		WS 22		0.7		4740.022
14	Ratchet wrench for 19 and 22 mm widths across flats, with reversing lever for right-hand and left-hand operation, mandrel for ring bolts	WS 19/22	0.32	0.6		4747.000
15	Scaffolding ratchet with reversing lever for right-hand and left-hand operation	WS 19	0.32	0.7		4726.019
		WS 22		0.7		4726.022
16	Scabbling pick 600 g reinforced		0.32	0.8		4421.051

WS = wrench size PU = packaging unit = available ex works = delivery time on request = only available in this packaging unit = the approval process is not yet completed

Anchoring, testing and measuring equipment, scaffolding identification

The scaffolding must be anchored vertically to and parallel with the façade with resistance to both tensile and compressive stress. Layher offers speedy and safe solutions:

Wall tie, 0.38 m 1, connected using one double coupler to an upright tube.

2 wall ties, 0.38 m 1, connected in a V shape with double couplers to the inner standard.

Wall ties, 0.95 m/1.45 m/1.75 m 1, connected using two double couplers to both upright tubes.

The optimum combination of the **ring screw 3** and **plastic wall insert 2** ensures high holding strengths. The high-quality welded connection prevents bending open of the eyelet.

The screw-in mark allows the screw-in process to be visually monitored.

High steel strength and zinc coating guarantee long-term use.

The anchoring forces in accordance with the approval or individual verification of structural strength can vary widely. The loading capacity of the anchoring, in particular of the anchoring foundation, must be carefully checked and verified. The load-bearing capacity of the plug connection must be checked with the Layher **plug-testing device 16** (see below) in accordance with our instructions for assembly and use. The plug test must be documented. Please comply with the plug manufacturer's installation instructions.

The **ETICS-tie** is constructed for carrying high loads, parallel to the façade, in use together with external thermal insulation compound systems. Assembly information, see instructions for assembly and use.

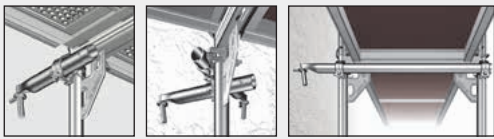

In our instructions for assembly and use, the plug-test is described. The regulations must always be respected.

Plug-testing device, hydraulic 16

Hand-operated, hydraulic plug-testing device in practical case, which allows plug-testing easily and reliably. With a continuous measuring range from 0 – 20 kN with a high accuracy of $\pm 2.5\%$. The test loads are shown on the manometer and recorded in the test report.

Identification and prohibition signs for work scaffolding as per DIN EN 12811-1.

The three-piece **scaffolding identification pad 18** with carbon copy developed to tag work scaffolding. The left part of the original will be put into the see-through pocket with Stopp T17. The right part is the inspection for your client. The carbon is kept by yourself for your files. On the back side of the original, important application notes are listed.

With the two-part **Speedy Vario wall tie system 14, 15** from Layher, it is now possible to freely anchor scaffolding, independently of the connector of the assembly frames, inside the scaffolding level – without any substantial reduction in the load capacity and without any complicated additional structures.

Further information to the **Speedy Vario wall tie system**, you can find in the Layher Info.

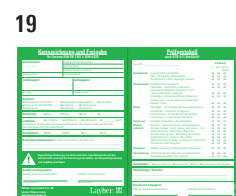
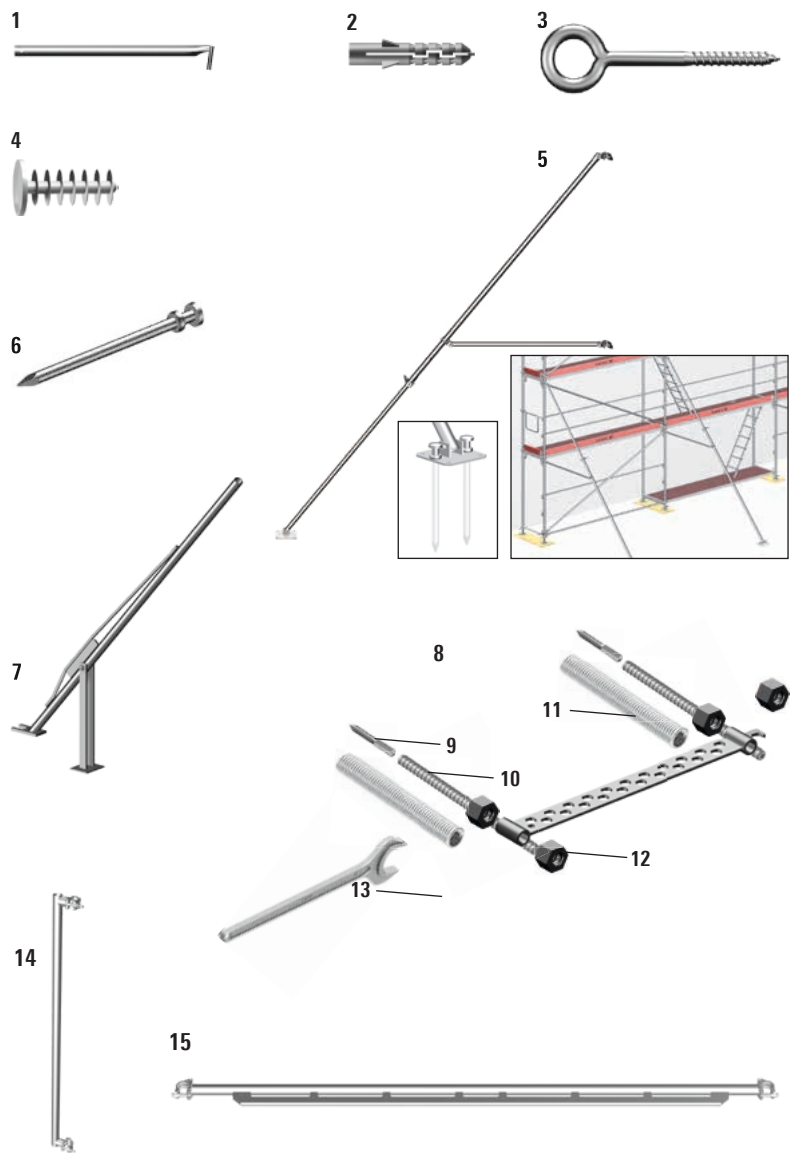

By using the **scaffolding lock**, you can secure your scaffolding against unauthorized alteration or dismantling. Use in topmost level instead of locking pins.

Pos.	Description	Dimensions L/H x W [m]	Weight approx. [kg]	PU [pcs.]	Ref. No.
1	Wall tie	0.38	1.6	250	1754.038
		0.69	2.8	50	1754.069
		0.95	3.7	50	1754.095
		1.45	5.7	50	1754.145
		1.75	5.8	50	1754.175
2	Plastic wall insert, plastic, drilled hole dia. 14 mm	70 mm	0.3	25	4008.071
		100 mm	0.3	25	4008.101
		135 mm	0.3	25	4008.136
3	Ring screw, steel, galvanized, dia. 12 mm, for expanding plug	95 mm	1.6	10	4009.096
		120 mm	1.8	10	4009.121
		190 mm	2.5	10	4009.191
		230 mm	3.0	10	4009.231
		300 mm	3.5	10	4009.301
		350 mm	5.0	10	4009.351
4	Cap, 12 mm, white, for expanding plug Ref. No. 4008	12 mm	1.0	100	4007.006
5	Telescopic stabilizer, 3.30 – 6.00 m	3.30	28.4	20	4032.600
6	Peg solid, dia. 24 mm	470 mm	1.8		4032.100
7	Peg extraction device		8.0		4032.200
8	ETICS-tie 600 complete, up to approx. 200 mm insulation ETICS-tie 800 complete, up to approx. 300 mm insulation comprising items 9, 10 (2 x), 11 (2 x) and 14 (4 x)	0.68	5.5	180	4000.600
		0.88	6.9	120	4000.800
9	ETICS hanger bolt, M12 x 125	125 mm	2.0	25	4000.126
10	ETICS-tie rod 380, up to approx. 200 mm insulation ETICS-tie rod 480, up to approx. 300 mm insulation	0.38	10.0	10	4000.121
		0.48	13.0	10	4000.481
11	Plastic pipe, 50 m		5.0		4000.050
12	Lock nut, WS 36 x 30		4.0	20	2671.131
13	Open ended wrench, WS 36		0.5	5	2671.135
14	Speedy Vario wall tie standard LW		8.9	25	1754.001
15	Speedy Vario wall tie ledger LW	1.57	9.0	25	1754.157
		2.07	12.1	25	1754.207
		2.57	15.0	25	1754.257
		3.07	17.7	25	1754.307
16	Plug-testing device, hydraulic for regulation testing of scaffolding anchoring, in practical equipment case	0.40	7.2		4012.001
17	Magnetic spirit level Aluminium section, milted measurement surface with V-channel, with 3 levels for horizontal, vertical and 45°-measuring, with innovative Neodym-magnet	0.25	0.4		4006.666
18	Scaffolding identification pad Pad with 50 + 50 pieces (Original + Carbon) with centre perforation and foldover as carbon-block	DIN A4	0.5		6344.500
19	See-through pocket for Ref. No. 6344.500 with lock flag when inspection record is not inserted.	0.30 x 0.17	0.4	10	6344.010
20	Scaffolding lock basic set, 20 locks, 2 keys and code card basic set, 20 locks, 2 keys and code card basic set, 50 locks, 4 keys and code card Expansion set with same locking as basic set, 20 locks Expansion set with same locking as basic set, 50 locks		2.2	10	4000.003
			4.2	20	4000.004
			10.5	50	4000.005
			4.2	20	4000.006
			10.5	50	4000.007

Suspend scaffolding

Economical solutions for corrosion prevention, refurbishment, ceiling work and much more.

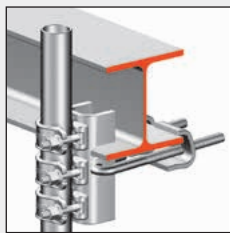

The **suspended scaffolding coupler 1** is suspended in existing brackets and I or U sections. With the three riveted-on half-couplers (for 48.3 mm scaffolding tubes) they have a permissible load of 15 kN.

The suspended scaffolding coupler must be secured with two **safety hooks 2**.

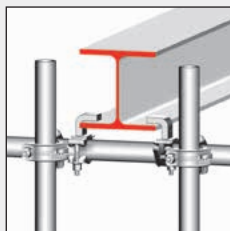

The **clamp couplers 3** for 48.3 mm scaffolding tubes are particularly advantageous for large flange widths. The connection to the flange is always made using two clamping couplers. Permissible load 9 kN per clamping coupler

in the vertical or horizontal direction.

The **beam gripper 6** is attached to the I beam. The connection to the scaffolding is made by means of the continuously adjustable **suspended scaffolding chain 5** with 2 shorter hooks, which can be connected to every chain link. The suspended structure with load hook can be subjected to a load of 15 kN per suspension point in the vertical direction. Expansion work is done with lattice beams 450 and decks. Suspended structures without load hook can be subjected to a load of 20 kN.

According to BGR 500, for sharp edges an edge protection must be used, if the edge radius is smaller than the nominal thickness of the suspending chain $R = 8 \text{ mm}$.

Dimensions of I beam:

Flange width max. 30 cm

Flange thickness max. 3.6 cm

Web thickness max. 1.9 cm

Corresponds to a wide I beam, series HE B 1000



Suspension in upright U or I sections. Maximum flange thickness 18 mm.



Two **safety hooks for suspended scaffolding coupler** secure the coupler Pos. 1 to the horizontal support flange. Maximum flange width of section 220 mm.



For suspending scaffolding tubes of dia. 48.3 mm on steel structures. Two pieces required.



Use as Clamp coupler

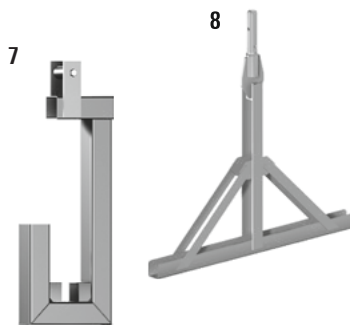
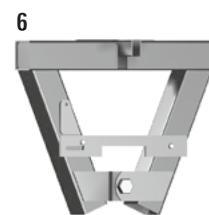

When using the load hook, the permissible load of the suspended structure is 15 kN.



Standard brick guard and protection for pedestrians

Protection net 9

The nets are attached at the bottom (at scaffolding deck height) and at the top (2 m above the scaffolding deck) to a tube.

With quick strap fasteners, the protection net is attached to the tubes at every 750 mm. A toe board and a handrail are required in any event.

Protection net 10.00 x 2.00 m, specification:

Mesh width 100 mm, blue, made of PPM 4.50 mm, knotless, as per DIN EN 1263-1, type U

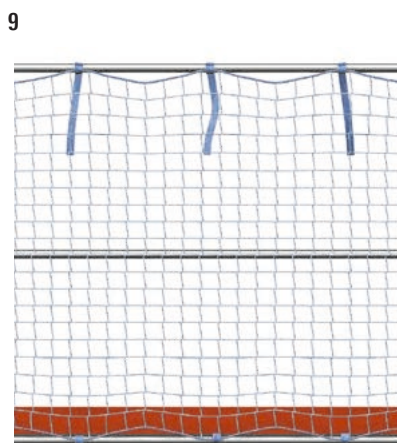

Pos.	Description	Dimensions L/H x W [m]	Weight approx. [kg]	PU [pcs.]	Ref. No.	
1	Suspended scaffolding coupler Permissible load: 15 kN Coupler secured by 2 securing hooks Pos. 2	WS 22		3.8	25	4713.022
2	Safety hook for suspended scaffolding coupler	SW 24	0.24	0.9	25	4714.000
3	Clamp coupler for I beam Permissible load 9 kN vertical or parallel to the tube axis	WS 19		1.1	25	4716.019
		WS 22		1.1	25	4716.022
4	Clamp half-coupler for I beam Permissible load: 3.6 kN vertical to the tube axis	WS 19		1.4	25	4750.019
		WS 22		1.4	25	4750.022
5	Suspended scaffolding chain. 4.00 m Permissible load: 20 kN Short link round steel chain dia. 8 mm, galvanized, for lifting purposes according to EN 818-2 grade 8 with 2 shorter hooks. About the chain inspection, a inspection certificate 3.1 can be issued according to EN 10204.	4.00		7.1		4015.444
6	Beam gripper automatically locking when closed Permissible load: 20 kN	0.50 x 0.41		11.2	45	4015.000
7	Load hook 450 for beam gripper Permissible load: 15 kN	0.68 x 0.24		6.9	40	4016.000
8	Lattice beam suspension for O-/U-lattice beams, 45 cm high	1.0 x 0.98 m		14.6		4017.000

Side protection nets must be checked every year!

Side protection nets may only be used within a year of their being tested. If older protection nets are used, it must be verified in tests that the maximum tensile strength of the net yarn is still at least 2 kN. This testing of your Layher side protection nets is free of charge for you.

To do so, a test mesh must be sent to Layher. In DIN EN 1263-1, Type U "Protection Nets and Protection Net Accessories, Safety Requirements, Testing" details are also given in 4.3 Instructions for Use, on the "time of removal from service".

Pos.	Description	Dimensions L/H x W [m]	Weight approx. [kg]	PU [pcs.]	Ref. No.	
9	Protection net with quick strap fastener	10.00 x 2.00		5.9		6232.002
10	Quick strap fastener	0.50		1.5	50	6235.001

WS = wrench size PU = packaging unit = available ex works = delivery time on request = only available in this packaging unit = the approval process is not yet completed

Parts for rolling towers

Castors

The mobile solution for birdcage, bridge or suspended scaffolding is often the best alternative in terms of technical suitability, scheduling and price. In this field too, the choice, the delivery capability and not least the experience of the manufacturer point to Layher. If scaffolding is made mobile using castors, DIN 4420-3 applies. For these rolling towers, verification of structural strength is required.

Robust castors with twin brake (it brakes wheel and slewing ring) for various loads, offer a safer mobility of the scaffolding – without high effort.

The spindels, which are inserted into the scaffolding standards offer an exact adjustment and lead the loads centrally into the wheel. This system offers highest stability and smooth production flows. For special applications, e.g. on sensitive floorings or work in explosive areas, we suggest the use of castors with polyurethane coatings (see article description). In scaffolding structures with a high proportion of permanent loads (e.g. dead weight), we recommend the use of the castor 1000 / 1200.

For rolling towers using **mobile beam with bar 6**. All the provisions of DIN 4420-3 must be met. This applies particularly for sufficient ballasting, safe internal access via hatch-type decks with ladders, and the necessary side protection on every deck level.

The **adjustable spigot 8** is fastened to the mobile beam with bar at the required point. For further extensions, the scaffolding elements are attached to the spigots. This permits flexible working on the ceiling or wall (in the middle or at the side).

For heavy rolling towers:

Double flange castor 9

For use on rails.

Steel wheel: External dia. 238 mm, internal dia. 200 mm. The bolted-on half-coupler permits, in conjunction with a scaffolding tube, locking and alignment of all the castors in the direction of travel.

Flange castor for 48.3 mm tube 10

For use on 48.3 mm tubes.

Steel wheel: External dia. 230 mm.

The welded-on half-coupler permits, in conjunction with a scaffolding tube, locking and alignment of all the castors in the direction of travel.

The scaffolding joints are secured with **locking pins 11** in special cases against unintentional lifting off, for example when scaffolding units are moved with a crane or in particular wind conditions.

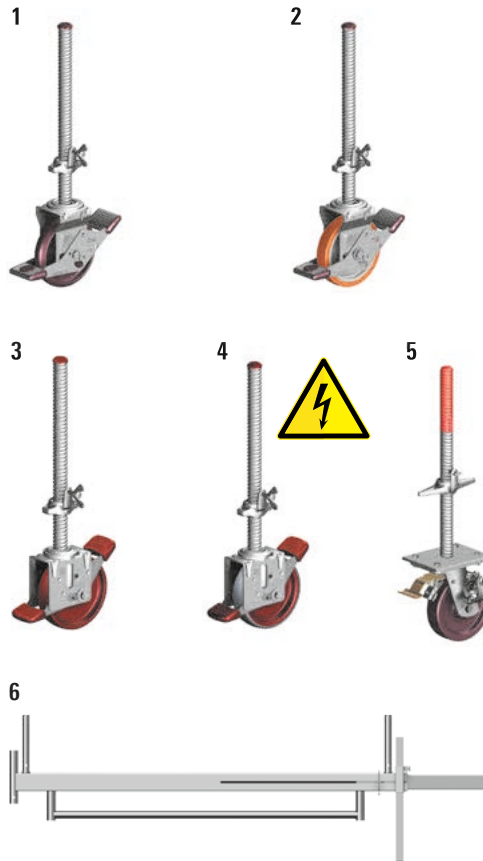





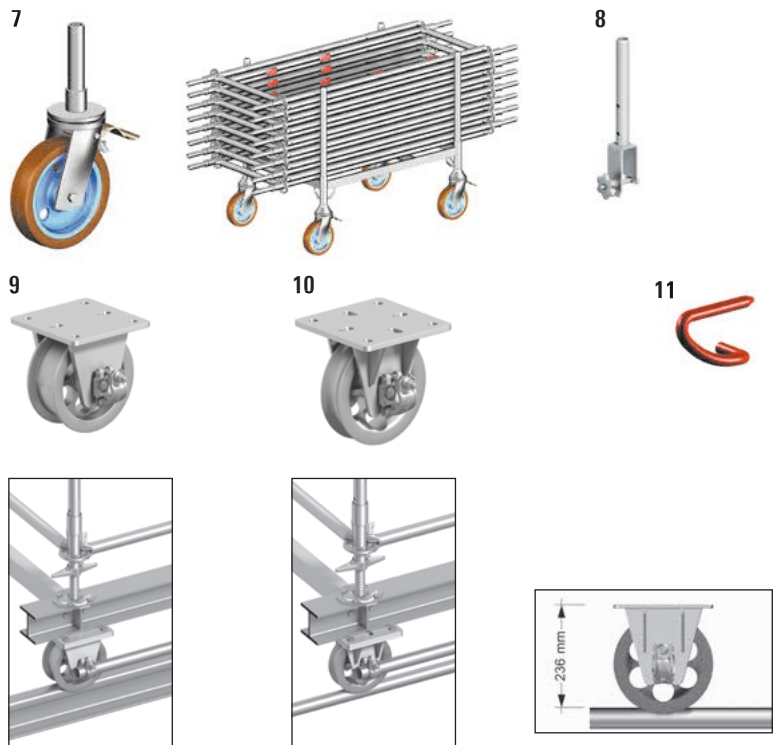

The welded-on halfcoupler permits, in conjunction with a scaffolding tube, locking and alignment of all the castors in the direction of travel.

The telescopic device: width max. 3.20 m, min. 2.30 m. The mobile beam can be used for all scaffolding systems (rolling towers, frame, modular and other scaffolding, tube-and-coupler) with a tube diameter of 48.3 mm.



Example for use:
Trolley with
doubleflange castor
on rails

Example for use:
Trolley with flange
castor on 48.3 mm
tube

Pos.	Description	Dimensions L/H x W [m]	Weight approx. [kg]	PU [pcs.]	Ref. No.
1	Castor 700 Plastic wheel, dia. 200 mm. With base plate, adjustment range 0.30 – 0.60 m, spindle nut with lock, castor with twinbrake lever and load centering when braked. Wheel and slewing ring can be locked. Permissible load capacity: braked 7.0 kN. Max. dynamic load 350 kg unbraked	dia. 0.20	6.8	70	1259.201
2	Castor 700, with polyurethane coating Plastic wheel dia. 200 mm. With base plate, adjustment range 0.30 – 0.50 m, spindle nut lock, castor with twin brake lever and load centering when braked. Wheel and slewing ring can be locked. Permissible load capacity: 7.0 kN. Max. dynamic load 350 kg unbraked	dia. 0.20	7.0	70	1259.202 
3	Castor 1000 Plastic wheel, dia. 200 mm. With base plate, adjustment range 0.30 – 0.60 m, spindle nut with lock, with twin brake lever and load centering when braked. Wheel and slewing ring can be locked. Permissible load: 10 kN (braked and unbraked)	dia. 0.20	6.3	70	1260.201
4	Castor 1000, with electroconductive polyurethane coating Plastic wheel dia. 200 mm of polyamide with coating of electroconductive polyurethane. With base plate, adjustment range 0.30 – 0.60 m, spindle nut lock, with twin brake lever and load centering when braked. Permissible load capacity: 10 kN (≈ 1.000 kg). Special castor for sensitive floorings and thanks to electroconductability also usable in explosive or ESD areas. Bleeder resistance according to DIN EN 12526 < 10 ⁴ Ω	dia. 0.20	6.8	70	1260.202 
5	Castor 1200, with half-coupler Reinforced plastic wheel, dia. 200 mm. With base plate, adjustment range 0.30 – 0.60 m, spindle nut with lock, wheel and slewing ring can be locked. Wheel and slewing ring can be locked. Permissible load: 12 kN (braked and unbraked)	dia. 0.20	12.0	50	1267.200 
6	Mobile beam with bar, 3.20 m, adjustable Steel rectangular tube, hot-dip galvanized. For base widening in special rolling tower structures.	3.20	42.6	20	1338.320
7	Castor 750, with polyurethane coating	dia. 0.25	11.3	50	5207.250 
8	Spigot, adjustable Steel, hot-dip galvanized. For use with mobile beam Ref. No. 1338.320	0.46	2.1	200	1337.000
9	Double flange castor, 75 mm Secured by top plate, hole pattern 170 x 170 mm, dia. 18 mm. external dia. 238 mm, internal dia. 200 mm, without brake. Permissible load: 31 kN	dia. 0.238	21.4		5216.076 
10	Flange castor for 48.3 mm tube Secured by top plate, outer hole pattern 170 x 170 mm, dia. 18 mm, inner hole pattern 126 x 126 x 13 mm (slot hole 13 x 28 mm) without brake. Permissible load: 31 kN	dia. 0.23	16.8		5221.048 
11	Locking pin, red, dia. 11 mm		0.2	100	4000.001

Scaffolding enclosures

Keder rail system

The Layher keder rail system is a weather protection system for scaffolding comprising **aluminium keder rails 1/2** and ready-made **keder tarpaulins**. It forms a continuous covering of the scaffolding surfaces to a level above the eaves of the building to be enclosed and is thus an almost watertight and dustproof enclosure. The aluminium keder rails are connected with **rail holders 5** and **capitive bolts 14**.

The wind loads that the weather protection system for scaffolding has to transmit must be calculated and verified in accordance with DIN EN 12810/12811. The spacing of the rail holders is max. 1 m. Transmission of forces must be structurally verified. Structural strength verifications are available for Layher scaffolding.

The load-bearing capacity of the keder rail system from Layher is designed such that scaffolding bays of up to 3.07 m can be used up to a height of 50 m. Above the 50 m level. The maximum possible scaffolding bay size is 2.57 m. The assembly instructions are available on request.

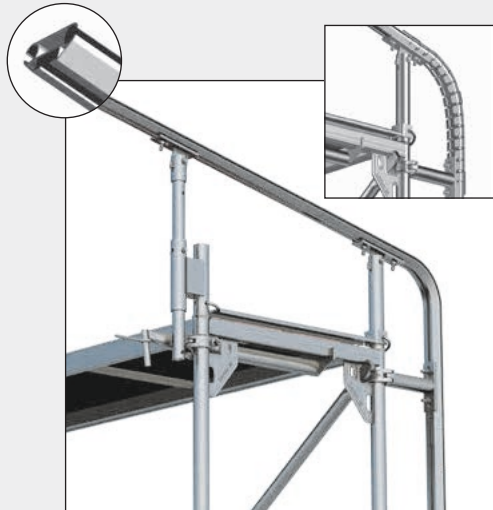

Keder tarpaulins in use on the scaffolding

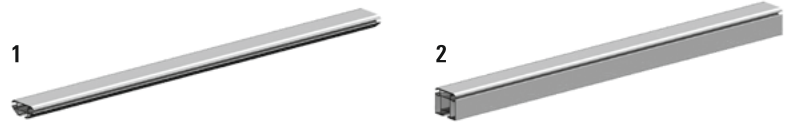

For tube diameter
48.3 mm



For connection to
Allround rosette

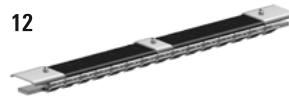

Angled connection between
two keder rails



Used to stabilize and secure the keder
tarpaulins at the tarpaulin closure / joint

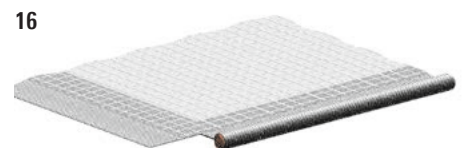
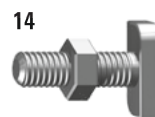

15



Lattice-reinforced and UV-stabilized PE tarpaulin with welded-on keder trim on both sides, dia. 13 mm. For scaffolding bay lengths of 2.07 m, 2.57 m and 3.07 m. Weight 300 g/m². Keder tarpaulins are available in other (e.g. metric) lengths and widths, please enquire for details.

Pos.	Description	Dimensions L/H x W [m]	Weight approx. [kg]	PU [pcs.]	Ref. No.
1	Aluminium keder rail 2000	1.30	2.0		4201.130
		2.00	3.0		4201.200
		2.25	3.3		4201.220
		2.50	3.8		4201.250
		3.00	4.5		4201.300
		4.00	6.0		4201.400
2	Aluminium keder rail 3000	2.00	6.1	20	5574.200
		3.00	9.2	20	5574.300
		4.00	12.2	20	5574.400
		5.00	15.3	20	5574.500
		6.00	18.3	50	5574.600
3	Aluminium keder bow 2000 eaves , for roof pitch 11°	0.80	1.7		4205.005
4	Aluminium keder bow 2000 ridge , for roof pitch 11°	0.30	0.5		4205.002
5	Rail holder with half-coupler , 19 WS 2 grooved bolts (Pos. 14) are required	0.20	1.7		4201.000
6	Rail holder with wedge head 2 grooved bolts (Pos. 14) are required	0.20	1.7		4201.001
7	Keder rail holder , rotatable	0.10	0.9		5573.000
8	Rail holder , swivelling with half-coupler	0.16	1.0		5573.006
9	Height adjuster for weather cap adjustable in 8 cm intervals, 2 grooved bolts (Pos. 14) are required	0.60	4.5		4203.000
10	Hinge fitting for weather cap 2 grooved bolts (Pos. 14) are required	0.30	1.6		4202.000
11	Hinge fitting for Event roof	0.70	3.4		5573.001
12	Keder bow 2000 flexible , 0.60 m	0.60	1.0		4205.003
13	Tube brace Steel, 2 grooved bolts (Pos. 14) are required. Metric and other lengths available on request	2.07	4.2	150	4204.207
		2.57	5.1	150	4204.257
		3.07	6.0	150	4204.307
14	Captive bolt for keder rail M12 x 40 , with nut		5.0	50	4206.001
15	Joint strap for aluminium keder rail 2 grooved bolts (Pos. 14) are required	0.17	0.5		4208.000
16	Keder tarpaulin 300 , white	10.00 x 2.07	5.9	10	6229.207
		10.00 x 2.57	7.3	12	6229.257
		10.00 x 3.07	8.7	10	6229.307

WS = wrench size PU = packaging unit = available ex works = delivery time on request = only available in this packaging unit = the approval process is not yet completed

Scaffolding enclosures

Scaffolding tarpaulins and nets

To protect passers-by and traffic during spraying work and other site work causing dirt, facade scaffolding is covered with tarpaulins and nets. Layher scaffolding tarpaulins and nets meet the requirements of DIN 4420-1. Compliance with design parameters prevents objects falling from the scaffolding level.

Scaffolding tarpaulins 1: Lattice-reinforced and UV-stabilized PE tarpaulin with eyelet bands welded on lengthways. For scaffoldings in the standard dimensions of 2.57 m and 3.07 m. Eyelet spacing 10 cm. For scaffoldings heights up to 10 m, minimum one fixation point per sqm is necessary. Above 10 m, there should be 2.

Scaffolding nets 2: Highly tear-resistant and UV-stabilized scaffolding protection net with fine fabric structure, gauze fabric of PP bands with three compressed eyelet bands. Eyelet spacing 10 cm. For scaffoldings in the standard dimensions of 2.57 m and 3.07 m.

Scaffolding tarpaulins and scaffolding nets are only supplied in rolls of 20 m length.

Scaffolding tarpaulins with printed advertising:
Delivery time and additional printing costs on request.

Load-capacity of the disposable tie:

Ref. No. 6242.001 (380 x 7.6) = 530 N

1

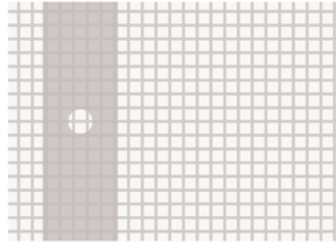

2

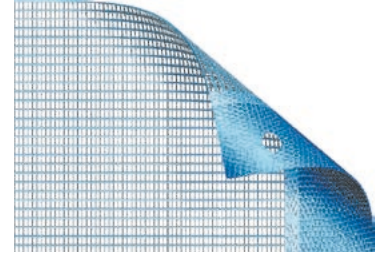

3

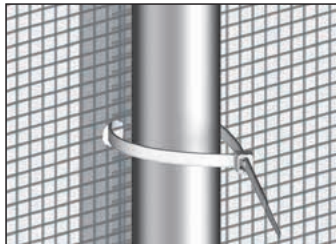

Ladder access



For constructing outward-facing accesses, **simple scaffolding ladders 4/5** are the ideal solution.

Layher pole ladders for scaffolding conform to DIN EN 131 individually or when connected to each other. The stile connections must have proper support and be secured with spring clips **7**.

The regulations in DGUV 38 must be followed. The **access ladder 6** is a flexible aid to climbing inside the scaffolding to a storey height of 2 m.

4



5



6



The stile sections of 7/8 are designed for dia. 48.3 mm coupler connection.

7



8











9



10



Pos.	Description	Dimensions L/H x W [m]	Weight approx. [kg]	PU [pcs.]	Ref. No.
1	Scaffolding tarpaulin 200 , white 2.70 m wide, working width 2.57 m 3.25 m wide, working width 3.07 m Lattice reinforced, very tearproof PE tarpaulin, 5 eyelet tapes, tear resistance approx. 750 N/5 cm, weight approx. 200 g/m ² , temperature resistance from -40 °C to +80 °C				
		20.00 x 2.70	10.8	46	6217.257
		20.00 x 3.20	13.0	46	6217.307
2	Scaffolding net 90 , blue Weight 90 g/m ² . 2.60 m wide, working width 2.57 m 3.20 m wide, working width 3.07 m				
		20.00 x 2.60	4.7	20	6219.257
		20.00 x 3.20	5.8	20	6219.307
3	Disposable tie for tarpaulins and nets , 380 x 7.6 mm		1.0	100 	6242.001

Pos.	Description	Dimensions L/H x W [m]	Weight approx. [kg]	PU [pcs.]	Ref. No.	
4	Aluminium pole ladder	10 rungs	2.90 x 0.46	8.2	50	1004.010
		14 rungs	4.00 x 0.46	11.3	50	1004.014
		17 rungs	4.90 x 0.46	13.8	50	1004.017
		20 rungs	5.70 x 0.46	16.1	50	1004.020
5	Steel pole ladder hot-dip galvanized	6 rungs	1.50 x 0.43	12.0	50	1002.006 
		8 rungs	2.00 x 0.43	15.0	50	1002.008 
		12 rungs	3.00 x 0.43	21.5	50	1002.012 
		16 rungs	4.00 x 0.43	28.0	50	1002.016 
6	Access ladder T15 , steel, 7 rungs for Allround Scaffolding and SpeedyScaf	2.15 x 0.35	7.6	70	4008.007	
7	Spring clip , 11 mm pin, for securing the joint connections of the extended simple steel/aluminium scaffolding ladder Ref. No. 1004/1002		0.1	200	1250.000	
8	Rubber base for tube 48.3 mm		0.1	100	1020.000	
9	Spare part foot , for 1004, 10 – 20 rungs, pair		0.1	2 	6492.028 	
10	Spare part foot , for 4005.007 and 4008007, pair		0.2	2 	6492.400 	

Scaffolding pallets

Tube pallets

in square shape (85) with or without skeleton box insert or in rectangular shape (125/265). The pallets are open on all sides. Tubes, standards, guardrails, diagonal braces, toe boards and, with the box insert, also couplers and other small parts are transported and stored with this pallet. The empty pallets, stored permanently in the base frame using pallet posts, can be transported and stored in a space-saving way.



Tube pallet 125 1

The following can be transported, for example:

- 13 Frames, 0.73 m or
- 80 Standards or
- 99 toe boards
- 155 ledgers (pay attention to the perm. load of 1.500 kg) or
- 11 Robust decks 0.61 m or
- 15 Stalu decks 0.61 m or
- 28 Steel decks 0.32 m.

Tube pallet 85 2

The following can be transported, for example:

- 500 couplers or
- 120 scaffolding anchors 0.38 m or
- 100 base plates 60

Tube pallet 265 3

The following can be transported, for example:

- about 13 Ridge cassettes or
- 20 Roof cassettes or
- 15 Brick guards.

Modular skeleton box 4

The skeleton box can be stacked with Euro pallets. Crane eyelets at top; an opening allows stacked material to be removed even if several pallets are stacked one above the other. The integrated timber base plate is 30 mm thick and it's nailed onto 50 x 50 mm square timbers.





The following can be transported, for example:

- 1.200 couplers or
- 180 scaffolding anchors 0.38 m or
- 200 base plates 60

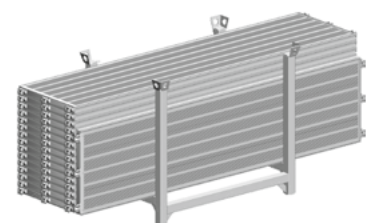
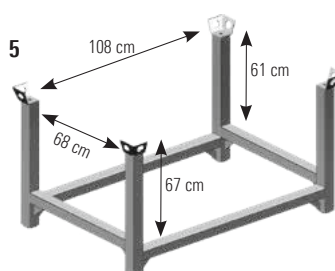
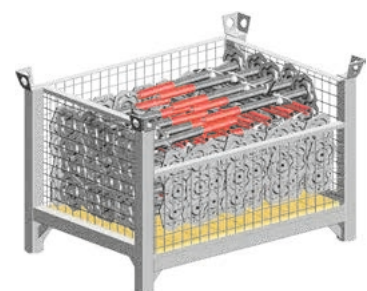
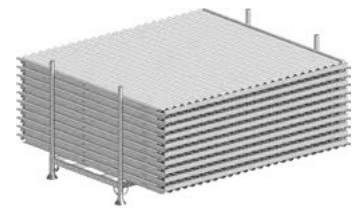
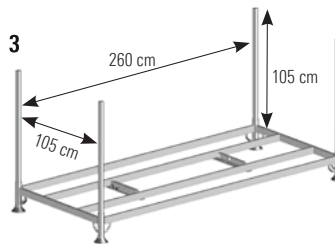
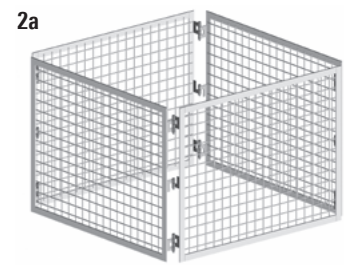
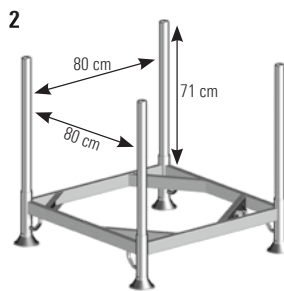
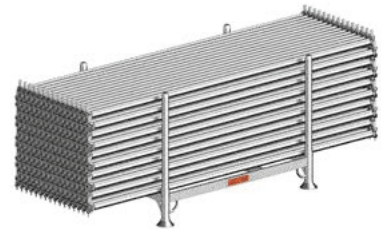
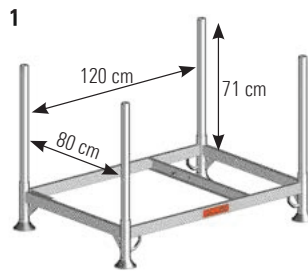
Modular pallet 5

The pallet is also stackable with Euro pallets and has crane eyelets. Thanks to the higher mounted cross struts, the storage goods can be placed by fork-lift truck.



Pos.	Description	Dimensions L/H x W [m]	Weight approx. [kg]	PU [pcs.]	Ref. No.
1	Tube pallet 125 Steel, hot-dip galvanized, length of pallet posts: 0.86 m, load 1,500 kg	1.37 x 0.97	32.0		5105.125
2	Tube pallet 85 Steel, hot-dip galvanized, length of pallet posts: 0.86 m, load 1,500 kg	0.97 x 0.97	30.8		5105.085
2a	Mesh box insert Steel, hot-dip galvanized, length of pallet posts: 0.86 m, load 1,500 kg	0.85 x 0.60	22.0		5104.086 
2b	Timber base plate	0.88 x 0.88	4.1		5104.088 
	Plug tubes for tube pallets 125 and 85	0.86	3.5		6494.751 
3	Tube pallet 265 Steel, hot-dip galvanized, length of pallet posts: 1.20 m, load 1,300 kg	2.77 x 1.22	50.6		5113.265 
4	Modular skeleton box Steel, hot-dip galvanized, internal dimensions 1.08 x 0.68 x 0.61 m load 2,000 kg, perm. onload 6,000 kg stackable with Euro pallets	1.20 x 0.80	85.80		5113.002
	Timber base plate for modular skeleton box IPPC treated = according to import regulations for packagings made of solid timber IPPC-Standard (International Plant Protection Convention)	1.07 x 0.76	15.2		6494.514 
5	Modular pallet Steel, hot-dip galvanized, internal dimensions 1.08 x 0.68 x 0.61 m load 2,000 kg, perm. onload 6,000 kg stackable with Euro pallets	1.20 x 0.80	45.0		7042.004

Bridging

The **aluminium stage 600 1** is a sturdy and versatile work deck of up to 10 m length which can be used quickly and easily as a lightweight aluminium component either individually or in scaffolding structures. In accordance with DIN EN 12811-1, the Layher **aluminium stage 600 1** with a width of 0.60 m is permissible for load class 3 (2 kN/m²; lengths up to 7.10 m) and also for load class 2 (1.5 kN/m²; lengths up to 10.00 m).

It can therefore be used as a deck in work, safety and birdcage scaffolding and also as a bridging element in façade scaffolding. If the height exceeds 2.00 m, a three-part brick guard is required.

Double guardrail with toe board 3

Folds together for transport

Guardrail fixing 4

for fastening the double guardrail to the aluminium bridging beam 600

Guardrail locking clip 5

for securing the double guardrail on the guardrail fixture

Guardrail post 1.20 m 6

for connecting the three-part brick guard made from scaffolding tubes, double couplers and toe boards. The **clamp 7** can be used to combine several aluminium bridging beams 600 as a platform for common support applications.

Alu telescopic stage 8

The automatic locking mechanism ensures that the inner extending element cannot slide out by mistake.

Toe board 9

Easy fitting into the toe board pins of the guardrail mounting standard, for complete three-part side protection.

The **steel plank 11** is a safe bridging element capable of bearing high loads for all scaffolding systems. It is preferred to wooden planks for use in areas with stringent fire protection requirements.

- ▶ Long service life, reusable
- ▶ Lower weight compared with wooden planks
- ▶ Non-slip and non-flammable
- ▶ Easy to secure in position with locking pins when placed on steel decks

The support length must be at least 10 cm at every support.

The steel planks 0.19 m and 0.32 m are also optionally available with one or with two pins.

See our Allround catalogue for this.

Individual toe boards

The toe boards can be individually designed in printing and painting.

Minimum order quantity 500 pcs.



Assembly with **guardrail post**, scaffolding tubes and double couplers



Assembly with **guardrail fixing** and **double guardrail with toe board**

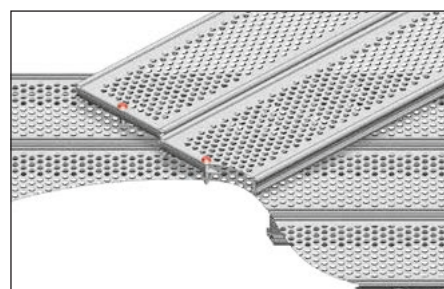
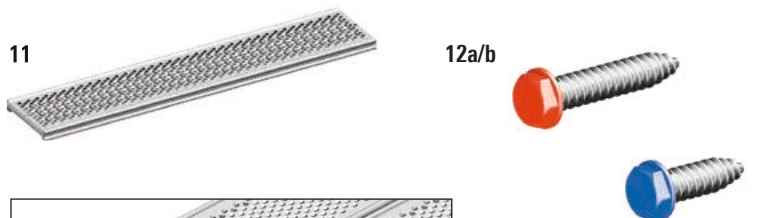
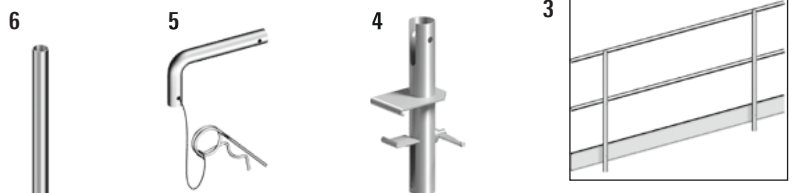

2 locking pins or 1 securing screw for each support secure the steel plank against slipping and lifting off.

Pos.	Description	Dimensions L/H x W [m]	Weight approx. [kg]	PU [pcs.]	Ref. No.			
1	Alu stage 600 	Permissible load-bearing capacity 2.0 kN/m ² , height 0.09 m	3.18 x 0.60	20.0	12	1348.318		
			4.12 x 0.60	26.0	12	1348.412		
			4.75 x 0.60	29.0	12	1348.475		
		Permissible load-bearing capacity 2.0 kN/m ² , height 0.12 m	5.20 x 0.60	38.0	16	1348.520		
			6.15 x 0.60	45.0	16	1348.615		
			7.10 x 0.60	52.0	12	1348.710		
		Permissible load-bearing capacity 1.5 kN/m ² , height 0.15 m	8.00 x 0.60	68.0	12	1348.800		
			9.10 x 0.60	76.0	12	1348.910		
			10.00 x 0.60	85.0	12	1348.100		
		2	Alu stage 600 folding	Perm. load-bearing capacity 1.5 kN/m ² , height 0.12 m	5.10 x 0.60	47.0	8	1349.510 
	7.30 x 0.60			61.0	8	1349.730 		
Perm. load-bearing capacity 1.5 kN/m ² , height 0.15 m	9.15 x 0.60			86.0	8	1349.915 		
3	Double guardrail, 2.00 m with toe board Aluminium	2.00 x 1.10	9.7	30	1332.200			
		Double guardrail, 3.00 m with toe board Aluminium	3.00 x 1.10	12.9	30	1332.300		
4	Guardrail fixing for Pos. 3, aluminium	0.36	0.9		1330.000			
5	Guardrail locking clip for Pos. 4, steel	0.08	0.1		1333.000			
6	Guardrail post, 1.20 m Aluminium	1.20	2.4		1334.000			
7	Clamp, steel	0.10	0.4		1331.000			
8	Alu telescopic stage	1.64 – 2.90 x 0.31	13.0	30	1351.290			
		1.92 – 3.50 x 0.31	16.0	30	1351.350			
		2.27 – 4.00 x 0.31	18.0	30	1351.400			
		2.49 – 4.40 x 0.31	20.0	30	1351.440			
9	Toe board, wood	1.57 x 0.15	3.1	140	1757.157			
		2.07 x 0.15	4.7	140	1757.207			
		2.57 x 0.15	5.6	140	1757.257			
		3.07 x 0.15	6.8	140	1757.307			
10	Locking pin for steel plank, plastic, dia. 11 mm	0.08	0.1	100 	3800.006			
11	Steel plank, 0.30 m	Load class 6	1.00 x 0.30	6.5	30	3880.100 		
		Load class 6	1.50 x 0.30	10.3	30	3880.150 		
		Load class 5	2.00 x 0.30	12.8	30	3880.200 		
		Load class 3	2.50 x 0.30	15.3	30	3880.250 		
	Steel plank, 0.20 m	Load class 6	1.00 x 0.20	4.8	100	3878.100 		
		Load class 6	1.50 x 0.20	7.2	100	3878.150 		
		Load class 5	2.00 x 0.20	9.5	100	3878.200 		
		Load class 3	2.50 x 0.20	11.8	100	3878.250 		
		12a	Securing screw, long, steel, hot-dip galvanized	19 WS	0.08 x 0.03	4.0	50 	3800.009 
				22 WS	0.08 x 0.03	3.9	50 	3800.010 
12b	Securing screw, short, steel, hot-dip galvanized	19 WS	0.04 x 0.02	2.3	50 	3800.011 		
		22 WS	0.04 x 0.02	2.3	50 	3800.012 		

WS = wrench size PU = packaging unit  = available ex works  = delivery time on request  = only available in this packaging unit  = the approval process is not yet completed

Bridging

The **steel gap sheet 1** and the **gap sheet 2** can be used between two scaffolding decks on SpeedyScaf and Allround Scaffolding. For use on gap widths up to 20 cm.

Advantages:

- ▶ Fast and easy mounting, independent of the gap width
- ▶ Long life
- ▶ Lightweight
- ▶ Cost effective
- ▶ Flexible use
- ▶ Not flameable
- ▶ Low height (h = 10 mm), meaning: low tripping hazard

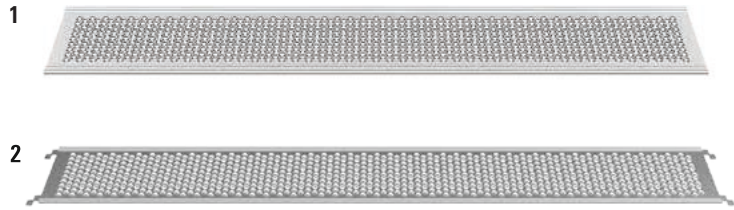

For 1



One securing screw (on page 29, Pos. 12 b) for each bearing secure the steel gap sheet against slipping and lifting off.

For 2

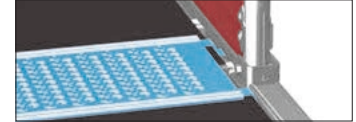

Securing is achieved by fitting an assembly frame and / or the bracket lift-off preventer. For Allround Scaffolding, the standard lift-off preventer is used.

Scaffolding planks

Our planks conform to sorting category S 10 as per DIN 4074. They can be used as scaffolding planks. They can be protected against splitting at the ends with **sheet metal fitting for plank 0.60 m 4**.

Scaffolding plank 3

freshly sawn, sorting category S 10

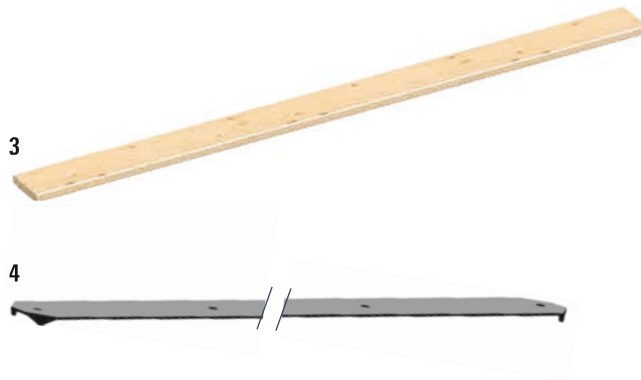

Software for scaffolding construction

Layher LayPLAN

Time and material are crucial factors in scaffolding construction. To make the most efficient use of both, the Layher range includes the practical LayPLAN scaffolding planning software.

With the several software packages LayPLAN CLASSIC and LayPLAN CAD, it is possible to plan scaffolding structures from simple, small facade scaffolding up to complex industrial scaffoldin or protective roofs and grandstands.

Once the dimensions and the required assembly variant have been entered, LayPLAN CLASSIC delivers within seconds a scaffolding proposal, including anchoring, bracing and side protection.

The data are then simply exported into LayPLAN CAD, which offers further possibilities for detailed 3D planning. A visual collision check is possible with the aid of volume rendering. Using a convenient search function with preview image, scaffolding planners will find not only an extensive library of individual Layher parts, but also assemblies already prefabricated for even faster design work.

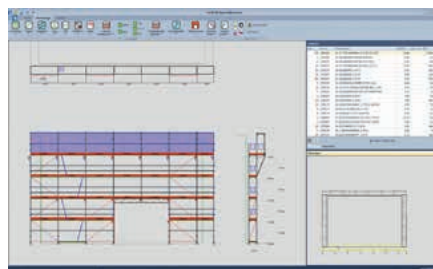

Speedy facade scaffolding with console brackets, brick guards and drive-trough cut-out

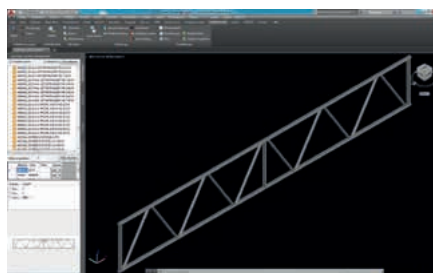

Planning of individual scaffolding structures with LayPLAN CAD

Pos.	Description	Use up to load class	Dimensions L/H x W [m]	Weight approx. [kg]	VE [St.]	Ref. No.
1	Steel gap sheet					
	for 0.73 m bay length	6	0.73 x 0.32	2.6	150	3881.000
	for 1.09 m bay length	6	1.09 x 0.32	3.8	150	3881.001
	for 1.57 m bay length	6	1.57 x 0.32	4.2	100	3881.002
	for 2.07 m bay length	6	2.07 x 0.32	6.3	100	3881.003
	for 2.57 m bay length	6	2.57 x 0.32	8.5	100	3881.004
	for 3.07 m bay length	6	3.07 x 0.32	12.0	100	3881.005
2	U-gap sheet					
	for 1.57 m bay length	6	1.57 x 0.32	4.5	100	3882.157
	for 2.07 m bay length	6	2.07 x 0.32	6.6	100	3882.207
	for 2.57 m bay length	6	2.57 x 0.32	8.8	100	3882.257
	for 3.07 m bay length	6	3.07 x 0.32	12.3	100	3882.307

Pos.	Description	Dimensions L/H x W [m]	Weight approx. [kg]	PU [pcs.]	Ref. No.
3	Scaffolding plank 45 mm high, freshly sawn, sorting category S 10	1.00 x 0.24	5.2	80	3816.100
		1.50 x 0.24	7.8	80	3816.150
		2.00 x 0.24	10.4	80	3816.200
		2.50 x 0.24	13.0	80	3816.250
		3.00 x 0.24	15.6	80	3816.300
		3.50 x 0.24	18.2	80	3816.350
		4.00 x 0.24	20.8	80	3816.400
4	Sheet metal fitting for plank 0.60 m	0.60	0.1		3817.000

How can I acquire LayPLAN?

Registration and all the ordering processes can be conveniently accessed at the Layher website: <http://software.layher.com>

A contact form gives you the data to access our software portal, where you can download a 30-day test version and also find the order form for the full version.

Pos.	Description	Ref. No.
5	LayPLAN CLASSIC scaffolding configurator for SpeedyScaf, Allround Scaffolding, weather protection roofs and rolling towers	6345.102
6	LayPLAN CAD plug-in for AutoCAD, for designing complex scaffolding in 3D and for developing scaffolding proposals from LayPLAN CLASSIC	6345.103

Fall protection

The **PSA-safety harness AX 60 C 1** has impressive features:

- ▶ Comfortable, padded and ergonomic back support
- ▶ Convenient tool holders and click-locks for easy fastening
- ▶ High operational dependability and absolute freedom from maintenance, plus very simple fastening
- ▶ Operating errors are not possible, as the equipment operates in any position
- ▶ Excellent running even under gruelling working conditions
- ▶ Enormous distribution of forces in the event of a fall

Before use, visual checks must be performed regularly to ensure correct working order. In accordance with German BGR 198 regulations, all personal safety equipment must be inspected at least once a year by an expert. The maximum permissible period of use for the equipment must not be exceeded.

The **advance guardrail post 4**, the **assembly guardrail 1.57/2.07 m 5**, the **assembly guardrail 2.57/3.07 m** and the **End-AGS 6** are used for temporary protection against falls during assembly of scaffolding parts on the uppermost, unsecured scaffolding level.

Extension lengths

Article	L min.	L max.
Assembly guardrail 1.57/2.07 m	1.57 m	2.90 m
Assembly guardrail 2.57/3.07 m	2.20 m	3.70 m

PSA: Personal safety apparatus

AGS: Advance guardrail system



Railing clamp 7

According to German regulations DGUV 38 relating to construction work, a fall protection system must be provided for work areas and walkways on roofs and intermediate levels where the height of the fall is more than 2.00 m. The Layher railing clamp meets these requirements for securing of concrete floors and fascias of 16 – 33 cm height and of flat roofs.

The back guard must be made in accordance with applicable regulations from tube/coupler, modular or frame scaffolding. The bay widths can be freely selected, max. 3.07 m long.

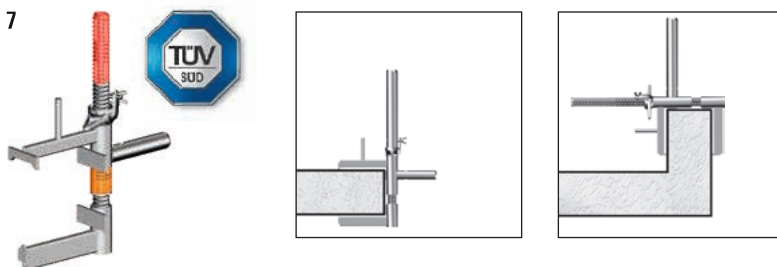
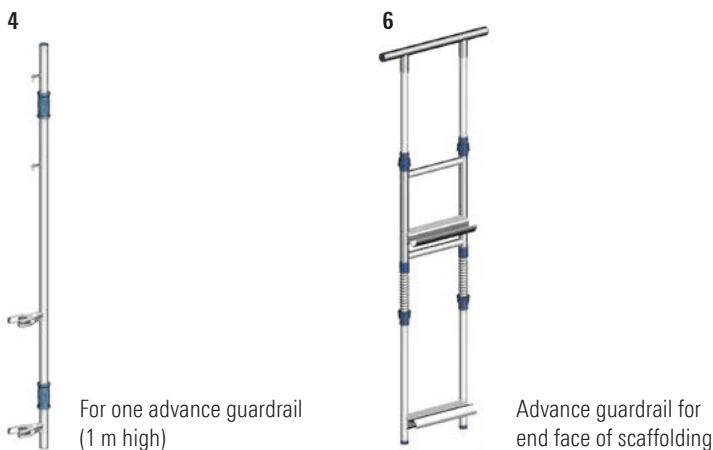

When attached the floors, toe boards must be provided, and the vertical stile must be attached over the spindle.

When attached to fascias, no toe boards are required, and the vertical stile must be attached over the spigot.

Pos.	Description	Dimensions L/H x W [m]	Weight approx. [kg]	VE [St.]	Ref. No.
1	PSA-safety harness AX 60 C , with extension 0.50 m conforms EN 361		1.8		5969.160
2	PSA-Flex-safety rope , 2.00 m with fall arrester and snap hook FS 90; as per EN 354 / EN 355 self-shortening to reduce tripping hazards	2.00 m	1.1		5969.501
3	PSA scaffolding construction set Pos. 1 and 2 Safety harness, safety rope 2.00 m, backpack (Use only in scaffolding construction)		3.5		5969.170
4	Advance guardrail post Aluminium for two advance guardrails (0.50 m and 1 m high); rapid attachment of guardrails with tilting pins	2.26	4.2	50	4031.002
5	Assembly guardrail , 1.57 / 2.07 m Assembly guardrail , 2.57 / 3.07 m Aluminium	1.65	3.2	50	4031.207
		2.15	4.0	50	4031.307
6	Advance guardrail system (AGS) for scaffolding front end Aluminium, single-part	2.20 x 0.70	9.8		4031.000
7	Railing clamp	0.58	7.0	40	4015.100

Example for use of the railing clamp on floor slab:

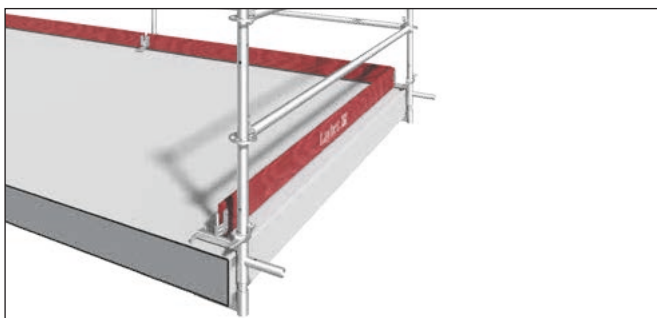

Example for use of the railing clamp on fascia:



WS = wrench size PU = packaging unit = available ex works = delivery time on request = only available in this packaging unit = the approval process is not yet completed

Vertical transport

Rope hoists

The rope hoist **Mini 60 S, Maxi 120 S and Maxi 150 S 1** is suitable for vertical transport of scaffolding material weighing from 6 up to 150 kg.

The winch is fastened to the scaffolding at the bottom. For assembly and dismantling of the scaffolding, only the swing arm has to be attached to the topmost scaffolding standard. The maximum working height of the hoist is 40 m, or 67 m if the winch is positioned higher.

The hoist winch is operated with 230 V/50 Hz. A slack rope switch shuts down the hoist when there is no longer any rope tension or when the end of the rope is reached. The hoist winch is equipped with an automatic final shutdown feature and a limiter against overloading of the hoist and scaffolding. For scaffolding hoists with a higher loading capacity, please request our special brochure. Loads additionally applied to the scaffolding must be transmitted into the structure or into the ground by special measures, and additional anchoring may be necessary. Please ask for further information about vertical transport.



Manual vertical transport

Bracket 12 with **hoist wheel 13** for manual vertical transport of scaffolding material weighing up to 50 kg. Loads additionally applied to the scaffolding must be transmitted into the structure or into the ground by special measures, and additional anchoring may be necessary.



Secure pulley 15

An integrated drop brake prevents the load from dropping when the rope is released and hence speeds up work procedures. The hoisted material is left suspended, thus permitting more flexible working both on the ground and on the scaffolding.

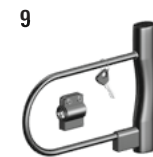
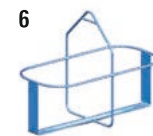
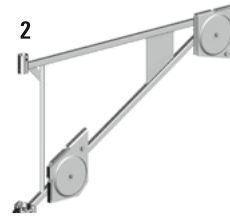
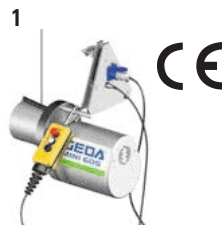

Pos.	Description	Dimensions L/H x W [m]	Weight approx. [kg]	VE [St.]	Ref. No.
1	Mini 60 S with 51 m of wire rope, catch and hook, control with emergency stop, 10 m, perm. load 60 kg hoisting speed 23/69 m/min		50.0		4415.060
	Mini 60 S with 81 m steel cable, otherwise as 4415.060		55.0		4416.116
	Maxi 120 S perm. load 120 kg, with 81 m steel cable, hoisting speed 20/60 m/min		65.0		4416.114
	Maxi 150 S perm. load 150 kg, with 81 m steel cable, hoisting speed 15/45 m/min		65.0		4416.115
2	Swing arm for Mini 60 S, Maxi 120 S and Maxi 150 S with deflecting wheel permissible load: 150 kg		11.7		4416.015

LOAD-BEARING EQUIPMENT

3	Load hook for scaffolding parts		0.5		4416.001
4	Hook holder for 5 load hooks		2.3		4416.014
5	Rope sling (5 mm dia., 35 cm long) for holding several load hooks		0.1		4416.002
6	Bucket holder for 2 buckets		4.4		4416.005
7	Lifting sling , 1.50 m for transport of scaffolding decks		0.5		4416.013

ACCESSORIES

8	Control unit , 30 m with emergency stop		7.0		4416.021	
		Control unit , 50 m with emergency stop		13.0	4416.055	
9	Security lock		1.1		4416.010	
10	Swing arm holder for Mini 60 S (fitted in any scaffolding level)		8.0		4416.003	
		Swing arm holder for Maxi 120 S and Maxi 150 S (fitted in any scaffolding level)		12.9	4416.779	
11	Wire rope , 51 m, 4.5 mm		4.5		4416.011	
		Wire rope , 81 m, 4.5 mm		6.3	4416.036	
12	Bracket , 0.73 m with eyelet for hoist wheel	WS 19	0.73	6.4	100	1744.719
		WS 22	0.73	6.4	100	1744.722
13	Hoist wheel up to max. 50 kg load, dia. 350 mm, with CE-mark	0.50 x 0.40	2.7		4419.000	
14	Shackle clip Connection of bracket with hoist wheel		0.2		4418.000	
15	Secure pulley up to max. 50 kg load, with CE-mark	0.40 x 0.40	5.0		4419.001	
16	Bracket adapter for hoist wheel Ref. No. 4419.001	0.26	1.4		4419.003	
17	Rope for hoist wheel , without drop brake Plastic rope, dia. 20 mm, for hoist wheel Ref. No. 4419.000; load capacity 50 kg; manufactured as per DIN EN 1261 Shape A; with spliced loops as per DIN 83 319; fitted at one end with 1 shackle clip as per DIN 82 101, colour blue	20 m	6.4		4420.200	
		40 m	6.1		4420.400	
18	Rope for hoist wheel , with drop brake Plastic rope, dia. 18 mm, for hoist wheel Ref. No. 4419.001, colour orange, otherwise as rope for hoist wheel without drop brake	20 m	6.4		4419.020	
		40 m	12.4		4419.040	

Vertical transport

Scaffolding construction hoist Layher 200

The **Layher 200** is suitable for vertical transport of scaffolding material weighing up to 200 kg and transport height of 35 m.

The **base unit 1** includes chassis, cable bin, trailing cable and control unit.

The mast with toothed rack can be fixed to the scaffolding using only one tube.

The anchoring distances are 4 m.

The entire unit only requires an area of 1.50 x 1.50 m on the ground, which makes it possible to load the hoist parallel to the building without any problems.

Unloading at the landing levels can be easily done by turning the platform.

The lightweight **platform 3** (only 51 kg) can be turned by 90° to the right.

The Layher 200 is easily serviced and maintained, i.e. easy access to handy components.

For stopping the loading platform in the right height, without mounting an additional position switch bracket, it is possible to place a **1.60 m ladder piece** directly above the base unit.

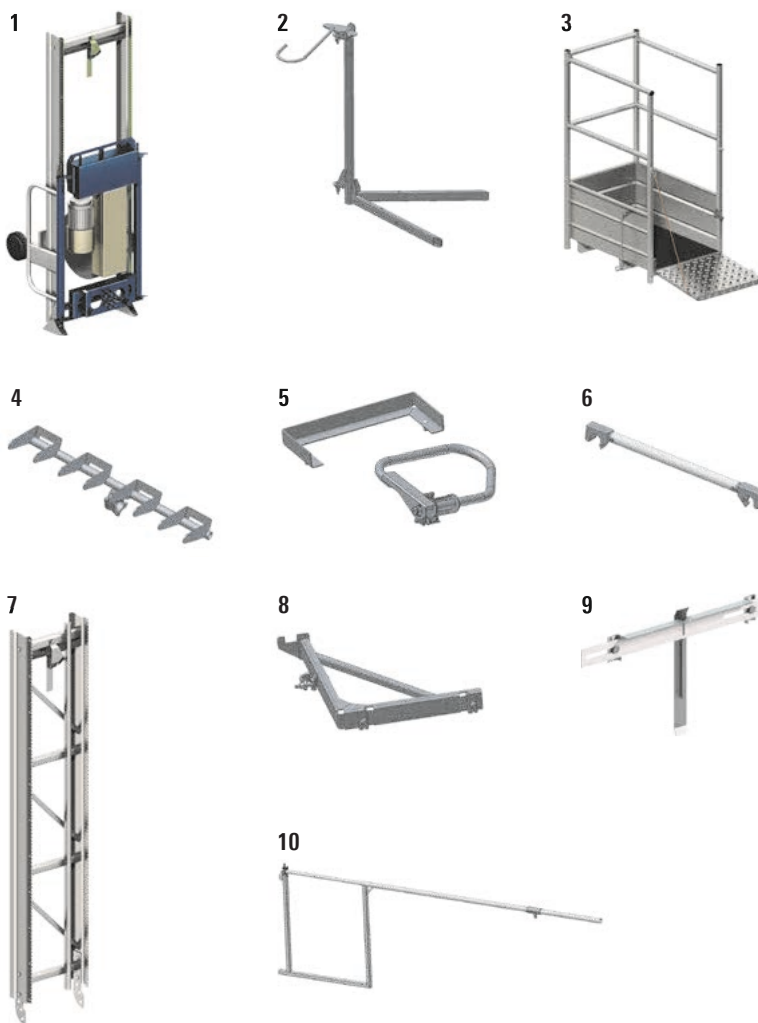

Please ask for further information about vertical transport.

Various accessories

Wood lacquer, red-brown 12

Painting or rolling: unthinned onto clean surface

Spraying: with 5% synthetic resin thinner onto cleaned surface

Dust-dry: about 45 mins.

Dry to touch: about 4 – 5 hrs.

Thoroughly dry: about 24 hrs.

The **tube end cap 17/18/19** is the visual closure for the tube and keeps out dirt, water and the like. It can be fitted over or into the tube.

For the use with aluminium tubes the spigots of the **tube end caps 18** and **19** must be cut longitudinally.

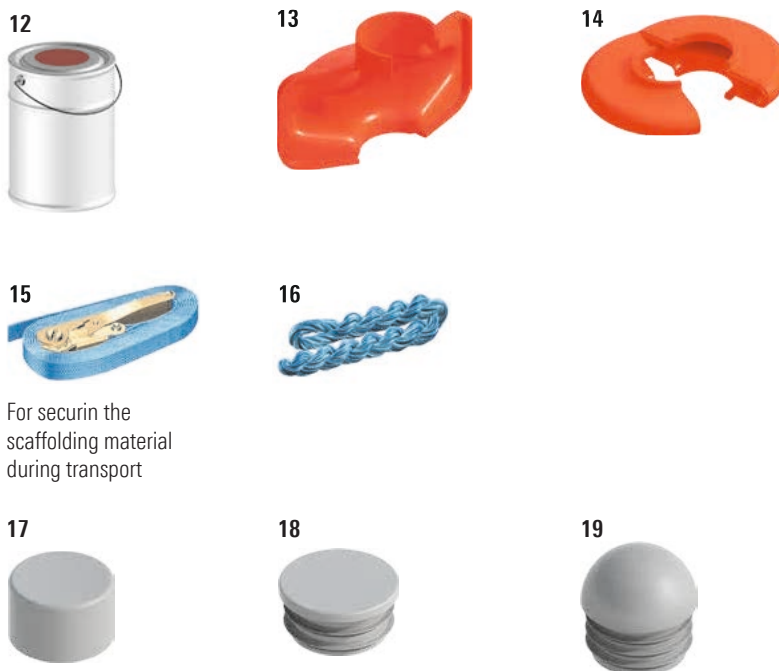

For securing the scaffolding material during transport

Pos.	Description	Dimensions L/H x W [m]	Weight approx. [kg]	PU [pcs.]	Ref. No.
1	Base unit Layher 200 1.7 kW / 230 VAC / 50 Hz, load capacity 200 kg, hoisting speed 25 m / min, max. hoisting height 35 m (Not allowed for passenger transportation) Scope of delivery: base part 2.00 m, electrical driven carriage, gripping device, control unit 5 m, cable bin, chassis		142.0		4416.883
2	Swivelling frame right, 90° swivelling		18.0		4416.822
3	Loading platform interior dimensions 1.20 x 0.75 x 1.80 m		51.0		4416.884
4	Holding rack for scaffolding parts (decks, toe boards or similar)		3.6		4416.885
5	Support for scaffolding tubes swivelling, 2-parts (with screwed on base bracket)		6.2		4416.886
6	Load secure bar with snap-on claws		2.4		4416.887
7	Ladder piece with toothed rack	2.00	24.0		4416.825
		1.60	20.3		4416.894
		1.00	14.0		4416.826
8	Ladder support holder spacings 4.00 m		9.4		4416.888
9	Position switch bracket for unloading break		2.6		4416.827
10	Advanced loading side guardrail for use with advance guardrail post (see page 34, Pos. 4)		9.3		4416.889
11	Cable extension, 20 m, for control unit, 5-pins		5.0		4416.331

Pos.	Description	Dimensions L/H x W [m]	Weight approx. [kg]	PU [pcs.]	Ref. No.
12	Wood lacquer, red-brown, 10 kg can		10.2		4020.000
13	Allround rosette cover with connected ledger Polyethylene, fixing with disposable tie 6241.001 (see page 25, Pos. 4)		0.7	10	4007.007
14	Allround rosette cover without connected ledger Polyethylene, fixing with disposable tie 6241.001 (see page 25, Pos. 4)		0.9	10	4007.008
15	Lashing strap with 0.5 t ratchet	4.00	0.2		6306.004
16	Poly cord, blue-white with fused ends, with spliced eyelet on one side, 3-strand, rope dia. 8 mm	2.50	1.0	10	4017.002
17	Tube end cap, dia. 48.3 mm, flat, external attachment Plastic		0.5	50	6494.532
18	Tube end cap, dia. 48.3 mm, flat, internal attachment Plastic		0.5	50	6494.534
19	Tube end cap, dia. 48.3 mm, round, internal attachment Plastic		1.0	50	6494.533

WS = wrench size PU = packaging unit = available ex works = delivery time on request = only available in this packaging unit = the approval process is not yet completed

Index

A			
Access ladder	24, 25		
Accessories, various	36		
Adjustable spigot	20, 21		
Adjustment plate	6, 7		
Advanced loading side guardrail	37		
Advance guardrail post	32, 33		
Advance guardrail system (AGS)	33		
Allround rosette cover			
with connected ledger	37		
without connected ledger	37		
Aluminium keder bow			
2000 eaves	23		
2000 ridge	23		
Aluminium keder rail	22, 23		
Aluminium lattice beam			
450	9		
750	8, 9		
Aluminium pole ladder	25		
Aluminium section beam with wood	10, 11		
Aluminium stage 600	28		
Aluminium system lattice beam	9		
Aluminium tri-lite beam	10, 11		
Aluminium U-profile with half couplers	10, 11		
Alu stage			
600	29		
600 folding	29		
Alu telescopic stage	28, 29		
Anchoring	16		
Assembly guardrail	32, 33		
B			
Base plate	6, 7		
60	7		
80	7		
150	7		
Base unit Layher 200	37		
Beam connector	10, 11		
Beam connector bolt	11		
Beam gripper	18, 19		
Bracket	34, 35		
Bracket adapter	35		
Bridging	28, 30		
Bucket holder	35		
C			
Cable extension	37		
Cap	17		
Captive bolt	22, 23		
Castor	20		
700	21		
750	21		
1000	21		
1200	21		
Clamp	28, 29		
Clamp coupler	18, 19		
Clamp half-coupler	19		
Collar nut standard thread M14	15		
Combination coupler	15		
Control unit			
30 m	35		
50 m	35		
Cover for coupler	15		
Crane eyelet coupler	15		
Cross head jack 45			
solid	6, 7		
D			
Disposable tie for tarpaulins			
and nets	25		
Double coupler	12, 13		
with coarse thread	13		
Double flange castor	20, 21		
Double guardrail			
2.00 m	29		
3.00 m	29		
with toe board	28		
E			
End-AGS	32		
ETICS hanger bolt	17		
ETICS-tie	16		
600 complete	17		
800 complete	17		
ETICS-tie rod			
380	17		
480	17		
Extension lengths	32		
F			
Fall protection	32		
Flange castor	20, 21		
G			
Gap sheet	30, 31		
General assembly and extension	12		
Guardrail fixing	28, 29		
Guardrail locking clip	28, 29		
Guardrail post	28, 29		
H			
Half-coupler	14		
with eye bolt	15		
with hook	12, 13		
with plate	15		
with toe board pin	15		
Head jack			
45, solid	7		
60, reinforced	7		
Height adjuster for weather cap	23		
Hinge fitting for weather cap	23		
Hoist wheel	34, 35		
Holding rack	37		
Hook holder	35		
I			
Individual toe boards	28		
Internal spigot	13		
J			
Joint strap for aluminium keder rail	23		
K			
Keder bow 2000 flexible	23		
Keder rail holder	23		
Keder rail system	22		
Keder tarpaulin	22, 23		
L			
Ladder access	24		
Ladder piece	37		
Ladder support	37		
Lashing strap	37		
Lattice beam	6, 8, 10		
Lattice beam connector	6, 8, 10		
Lattice beam coupler	12, 13		
Lattice beam hinged pin	8, 9		
Lattice beam mounting	10, 11		
Lattice beam pin	8, 9		
Lattice beam suspension	19		
Layher 200	36		
LayPLAN	30		
LayPLAN CAD	31		
LayPLAN CLASSIC	31		
Lifting sling	35		
Load hook	35		
450	19		
Loading platform	37		
Load secure bar	37		
Locking pin	20, 21, 29		
Lock nut	17		
M			
Magnetic spirit level	17		
Measuring equipment	16		
Mesh box insert	27		
Mobile beam with bar	20, 21		
Modular pallet	26, 27		
Modular skeleton box	26, 27		
O			
Open ended wrench	17		
P			
Parts for rolling towers	20		
Passageway marking	8, 9		
Peg extraction device	17		
Peg solid	17		
Plastic pipe	17		
Plastic wall insert	16, 17		
Platform	36		
Plug-testing device	16, 17		
Plug tubes	27		
Poly cord	37		

Position switch bracket	37	Sheet metal fitting	30, 31	V	
Protection for pedestrians	18	Simple scaffolding ladders	24	Vertical transport	34, 36
Protection net	18	Sleeve coupler	13	W	
with quick strap fastener	19	Software for scaffolding construction	30	Wall tie	17
Protective base for base plate	6, 7	Spare part foot	25	0.38 m	16
PSA-Flex-safety rope	33	Special bolt		0.95 m/1.45 m/1.75 m	16
PSA-safety harness AX 60 C	32, 33	M12 x 60	9	Wedge double coupler	13
PSA scaffolding construction set	33	M12 x 60 mm	8	Wedge half-coupler	14, 15
Q		M14 x 65	9	Wedge spindle swivel coupler	13
Quick strap fastener	19	M14 x 65 mm	8	Wedge swivel coupler	12, 13
R		Speedy Vario Wall Tie System	16, 17	Wire rope	
Rail holder	22, 23	Spigot with half coupler	15	51 m	35
with half-coupler	23	Spring clip	25	81 m	35
with wedge head	23	Squared timber coupler		Wood lacquer	36, 37
Railing clamp	32, 33	large	15		
Ratchet spanner	15	small	15		
Ratchet wrench	15	Standard brick guard	18		
Reduction double coupler	13	Steel gap sheet	30, 31		
Reduction swivel coupler	13	Steel lattice beam 750	8, 9		
Ring screw	16, 17	Steel plank	28		
Rope for hoist wheel	35	0.20 m	29		
with drop brake	35	0.30 m	29		
Rope hoist	34	Steel pole ladder	25		
Maxi 120 S	34, 35	Steel system lattice beam	7		
Maxi 150 S	34, 35	Steel tube	12, 13		
Mini 60 S	34, 35	Support for scaffolding tubes	37		
Rope sling	35	Suspended scaffolding chain	18, 19		
Rubber base	25	Suspended scaffolding coupler	18, 19		
Rubber pad for base plate	7	Suspend scaffolding	18		
S		Swing arm	35		
Safety clip	8, 9	Swing arm holder	35		
Safety hook	18, 19	Swivel coupler	13		
Scabbling pick	14, 15	with coarse thread	13		
Scaffolding construction hoist Layher 200	36	Swivelling base plate 60			
Scaffolding coupler	12, 14	reinforced	7		
Scaffolding enclosures	22, 24	Swivelling frame	37		
Scaffolding identification	16	Swivelling head jack	6, 7		
Scaffolding identification pad	16, 17	T			
Scaffolding lock	16, 17	T-bolt			
Scaffolding net	24, 25	standard thread M14	15		
Scaffolding pallet	26	Telescopic stabilizer	17		
Scaffolding plank	30, 31	Testing equipment	16		
Scaffolding ratchet	15	Three-point base plate	10, 11		
Scaffolding tarpaulin	24	Timber base plate	27		
200	25	Toe board	28, 29		
Scaffolding tube	12, 13, 14	Tri-strut LW	10, 11		
Section beams	10	Tube brace	23		
Secure pulley	34, 35	Tube end cap	36, 37		
Securing screw		Tube pallet	26		
long	29	85	26, 27		
short	29	125	26, 27		
Security lock	35	265	26, 27		
See-through pocket	17	U			
Shackle clip	35	Unit beam spigot	8, 9		
		round steel	8, 9		
		Universal U-Lift-off preventer	11		

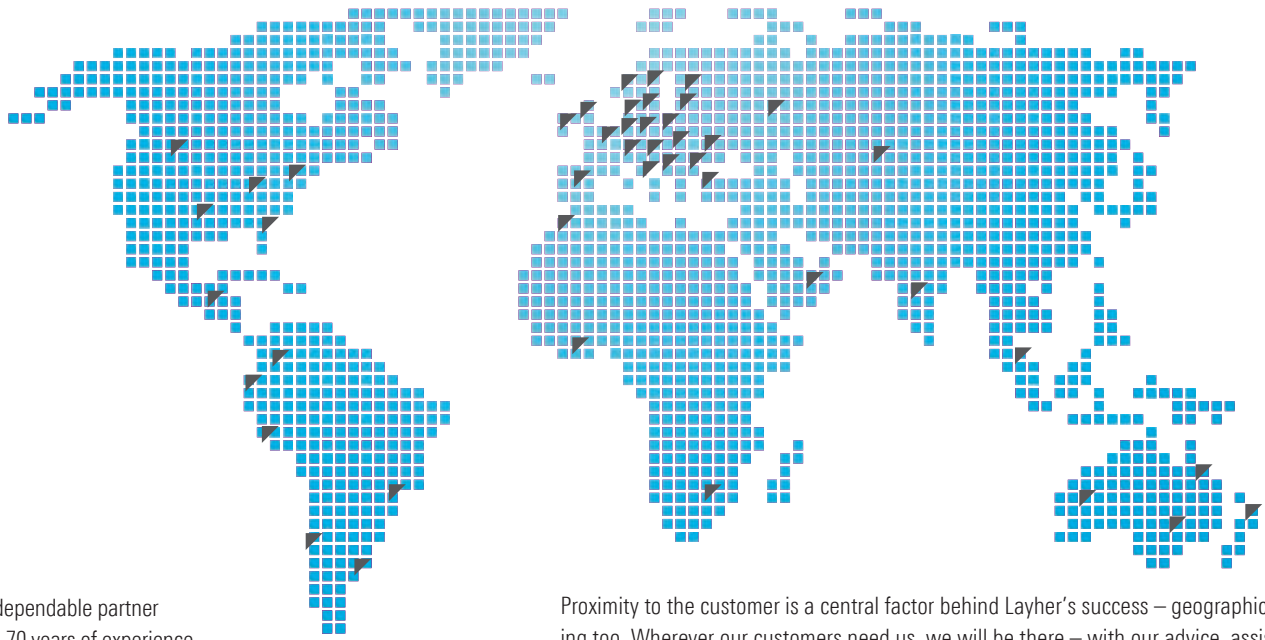

Layher is your dependable partner with more than 70 years of experience. "Made by Layher" always means "Made in Germany" too – and that goes for the entire product range. Superb quality – and all from one source.

Proximity to the customer is a central factor behind Layher's success – geographically speaking too. Wherever our customers need us, we will be there – with our advice, assistance and solutions.

-  **SpeedyScaf**
-  **Allround Scaffolding**
-  **System-free Accessories**
-  **Protective Systems**
-  **Shoring**
-  **Event Systems**
-  **Rolling Towers**
-  **Ladders**



Headquarters in Eibensbach



Plant 2 in Gueglingen

Layher 

More Possibilities. The Scaffolding System.

Wilhelm Layher GmbH & Co KG
Scaffolding Grandstands Ladders

Ochsenbacher Strasse 56
74363 Gueglingen-Eibensbach
Germany

Post Box 40
74361 Gueglingen-Eibensbach
Germany
Telephone +49 (0) 71 35 70-0
Telefax +49 (0) 71 35 70-2 65
E-mail export@layher.com
www.layher.com

